

ELLIS

Holding Power

DATA SHEET

TWIST FOOT VULCAN+ (VRT)

- BASE FIXING KIT DESIGNED FOR FAST INSTALL ON 41X41 AND 41X21 UNISTRUT CHANNEL/LADDER
- CLEAT COMES WITH ALL FIXINGS IN PLACE READY FOR INSTALL, NO EXTRA FIXINGS ARE REQUIRED ON SITE
- FIXING KIT CAN BE SUPPLIED IN A4 STAINLESS STEEL, GALVANISED STEEL OR ZINC PLATED STEEL
- SHORT CIRCUIT AND MECHANICALLY TESTED TO IEC 61914 - REFER TO VRT+ DATA SHEET

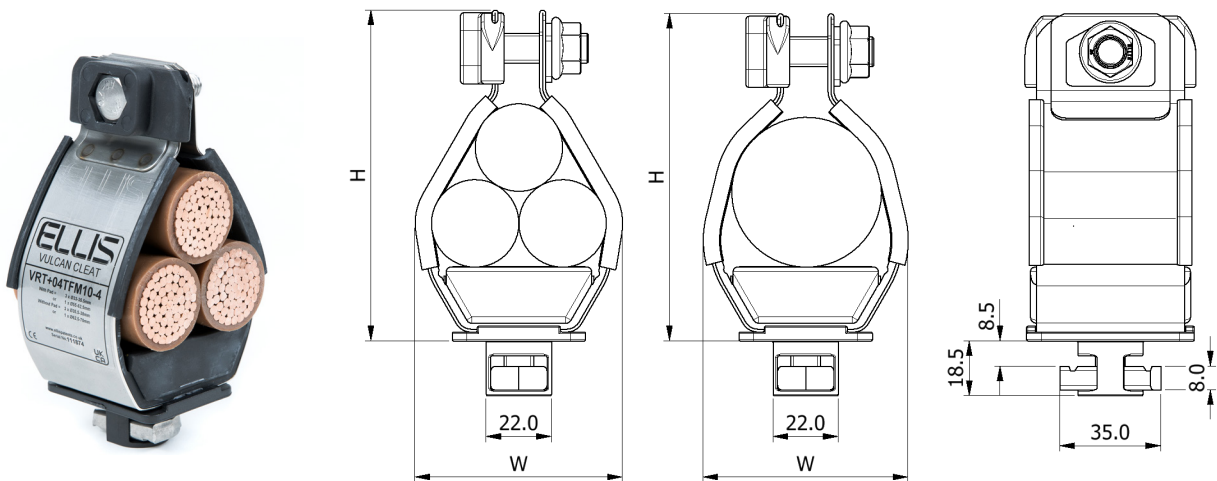

SINGLE FIX TWIST FOOT: VRT+00 TO VRT+12

VRT+ TWIST FOOT OPTIONS

PART NO.	CABLE RANGE TREFOIL		CABLE RANGE SINGLE		DIMENSIONS (mm)			WEIGHT (g)
	MIN ϕ (mm)	MAX ϕ (mm)	MIN ϕ (mm)	MAX ϕ (mm)	W	H	D	
VRT+00TFM10-X	19	24	30	42	60	96	54	301
VRT+01TFM10-X	23	28	38	50	63	102	54	308
VRT+02TFM10-X	27	32	43	58	72	109	54	319
VRT+03TFM10-X	30	35	49	64	79	115	54	329
VRT+04TFM10-X	33	38	55	70	85	121	54	334
VRT+05TFM10-X	36	42	58	75	96	128	54	369
VRT+06TFM10-X	40	46	63	84	105	137	54	381
VRT+07TFM10-X	44	50	73	90	112	143	54	441
VRT+08TFM10-X	48	55	83	100	121	152	54	455
VRT+09TFM10-X	51	58	86	104	126	158	54	461
VRT+10TFM10-X	55	62	88	110	134	166	54	492
VRT+11TFM10-X	59	66	90	115	143	174	54	503
VRT+12TFM10-X	63	70	100	125	152	181	54	510
VRT+13TFM10-X	67	74	107	132	161	188	70	525
VRT+14TFM10-X	71	78	120	145	169	195	70	636
VRT+15TFM10-X	74	82	125	150	176	199	70	642
VRT+16TFM10-X	77	85	132	153	183	208	70	644
VRT+17TFM10-X	81	89	136	156	190	219	70	718
VRT+18TFM10-X	85	93	139	159	200	228	70	728
VRT+19TFM10-X	89	97	142	162	200	238	70	737
VRT+20TFM10-X	93	101	160	170	215	243	70	746

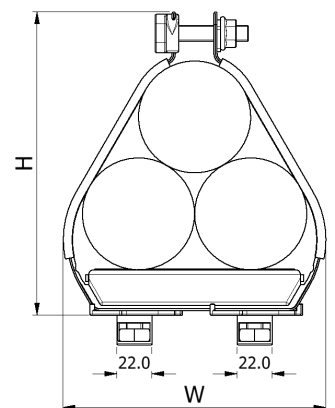

TWIN FIX TWIST FOOT:
VRT+13 TO VRT+20

'X' DENOTES FIXING MATERIAL, OPTIONS ARE AS FOLLOWS:

4 = A4 STAINLESS STEEL
G = GALVANISED STEEL
Z = ZINC PLATED STEEL

E.G A VRT+04 WITH STAINLESS STEEL TWIST FOOT FIXINGS BECOMES: VRT+04TFM10-4

INSTALLATION OVERVIEW

SINGLE FIX TWIST FOOT: VRT+00 TO VRT+12

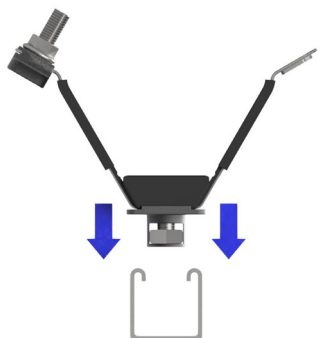

1) Lower the cleat through the gap in the channel.



2) Once lowered twist the cleat 90°.



3) Tighten the M10 bolt in the base of the cleat.

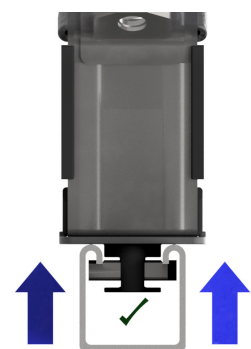

4) As the bolt is tightened the channel nut will move up the twist foot base and grip onto the channel.



5) The cleat is now securely fastened to the structure and is ready to accept the cables.

TWIN FIX TWIST FOOT: VRT+13 TO VRT+20



1) Lower the cleat through the gap in the channel.



2) Rotate both twist foot bases through 90° into the locking position.



3) Tighten both bolts in the base of the cleat to the same torque value.



4) As the bolts are tightened the channel nuts will move up the twist foot base and grip onto the channel.



5) The cleat is now securely fastened to the structure and is ready to accept the cables.

This data sheet is subject to change without notice. The information provided has been generated in laboratory conditions, as such results in use may vary.