

# ELLIS

Holding Power

## DATA SHEET

### TWIST FOOT EMPEROR SINGLE

- BASE FIXING KIT DESIGNED FOR FAST INSTALL ON 41X41 AND 41X21 UNISTRUT CHANNEL/LADDER
- CLEAT COMES WITH ALL FIXINGS IN PLACE READY FOR INSTALL, NO EXTRA FIXINGS ARE REQUIRED ON SITE
- FIXING KIT CAN BE SUPPLIED IN A4 STAINLESS STEEL, GALVANISED STEEL OR ZINC PLATED STEEL
- SHORT CIRCUIT AND MECHANICALLY TESTED TO IEC 61914 - REFER TO EMPEROR SINGLE DATA SHEET

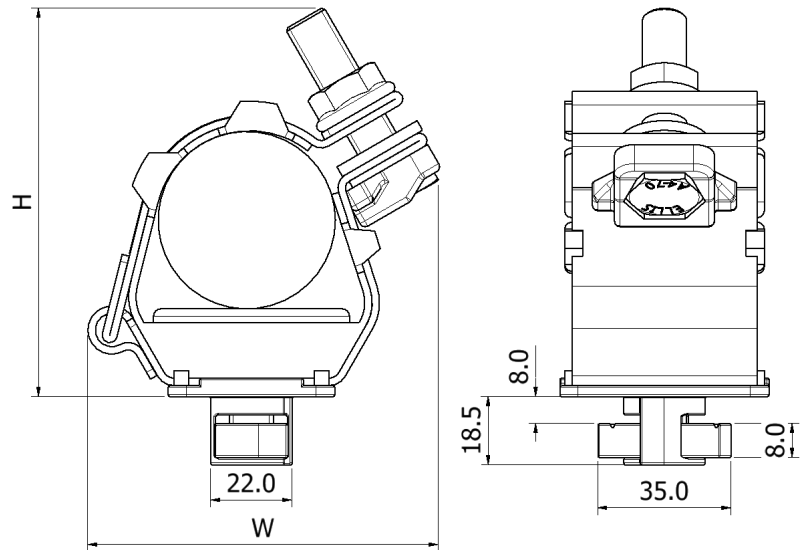

EMPEROR SINGLE TWIST FOOT OPTIONS

SINGLE FIX TWIST FOOT: ES32-39 TO ES94-118

PART NO.	CABLE RANGE		DIMENSIONS (mm)			WEIGHT (g)
	MIN $\phi$ (mm)	MAX $\phi$ (mm)	W	H	D	
ES32-39TFM12-X	32	39	91	92	54	500
ES37-45TFM12-X	37	45	96	96	54	520
ES44-52TFM12-X	44	52	99	101	54	530
ES51-59TFM12-X	51	59	103	105	54	540
ES58-66TFM12-X	58	66	109	104	54	550
ES65-73TFM12-X	65	73	111	106	54	560
ES73-85TFM12-X	73	85	135	115	54	690
ES84-94TFM12-X	84	94	135	138	54	710
ES94-118TFM12-X	94	118	160	153	54	760
ES118-130TTFM10-X	118	130	175	163	70	1000
ES127-150TTFM10-X	127	150	180	183	70	1040

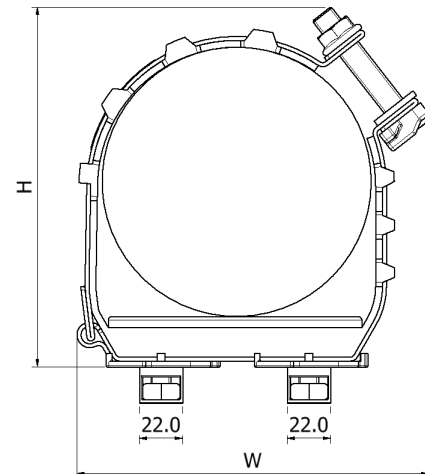

TWIN FIX TWIST FOOT: ES118-130 TO ES127-150

X DENOTES FIXING MATERIAL, OPTIONS ARE AS FOLLOWS:

4 = A4 STAINLESS STEEL

G = GALVANISED STEEL

Z = ZINC PLATED STEEL

E.G A ES37-45 WITH STAINLESS STEEL TWIST FOOT FIXINGS BECOMES: ES37-45TFM10-4

ELLIS PATENTS LTD.

[www.ellispatents.co.uk](http://www.ellispatents.co.uk)

ISSUE 02 03/02/22

1 / 2

#### INSTALLATION OVERVIEW

SINGLE FIX TWIST FOOT: ES32-39 TO ES94-118

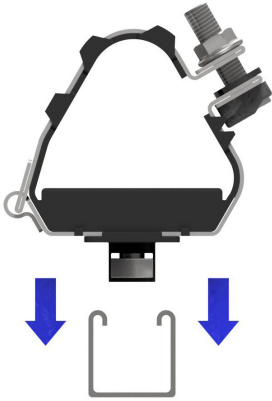

1) Lower the cleat through the gap in the channel.

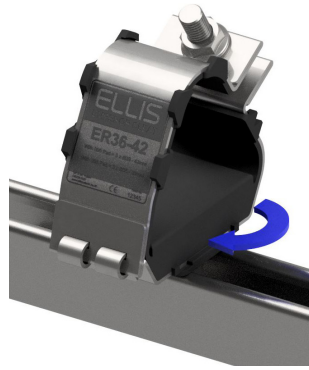

2) Once lowered twist the cleat 90°.

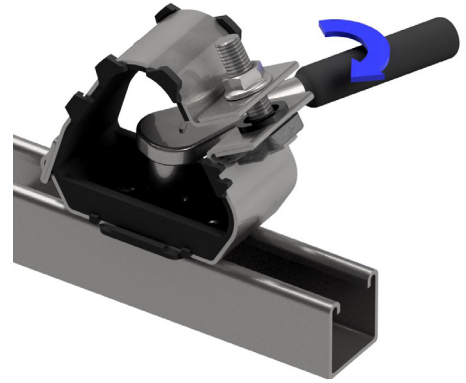

3) Tighten the M10 bolt in the base of the cleat.

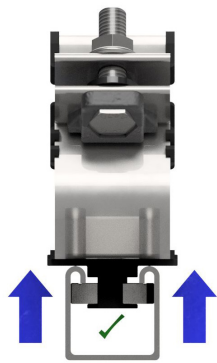

4) As the bolt is tightened the channel nut will move up the twist foot base and grip onto the channel.



5) The cleat is now securely fastened to the structure and is ready to accept the cables.

TWIN FIX TWIST FOOT: ES118-130 TO ES127-150

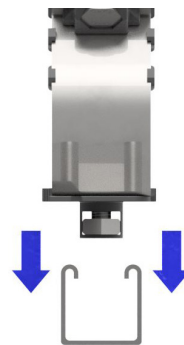

1) Lower the cleat through the gap in the channel.

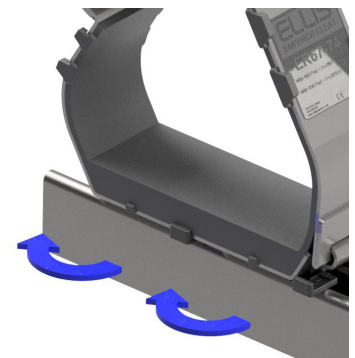

2) Rotate both twist foot bases through 90° into the locking position.

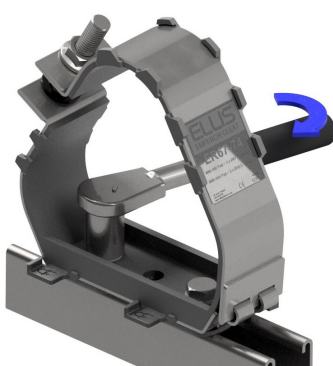

3) Tighten both bolts in the base of the cleat to the same torque value.

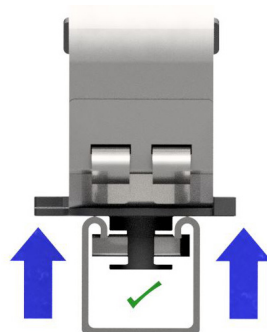

4) As the bolts are tightened the channel nuts will move up the twist foot base and grip onto the channel.



5) The cleat is now securely fastened to the structure and is ready to accept the cables.

This data sheet is subject to change without notice. The information provided has been generated in laboratory conditions, as such results in use may vary.