

ELLIS

Holding Power

CABLE HANGERS

TRIED. TESTED. TRUSTED.
WORLDWIDE



AT A GLANCE

We are a global leader in the design and manufacture of safety-critical cable management products, with over 60 years of innovation and engineering expertise at our heart.

At Ellis, technical excellence means pushing beyond perceived limitations in product design and performance. We don't simply meet the technical regulations requirements; we challenge them through rigorous testing, engineering insight and real-world application. By taking a holistic approach to product specification, we consider the full range of environmental, mechanical and operational pressures that installations may face over their lifetime. This commitment allows us to deliver cable management solutions that provide proven restraint, long-term reliability and enhanced safety, even in the most demanding conditions.



Global leader in cable management innovation and safety.



Trusted worldwide across energy, utilities, oil & gas, rail and renewables



Proven performance – rigorously tested to international standards



Consistently achieving the highest standards of ISO accreditation



Bespoke solutions to meet project-specific needs

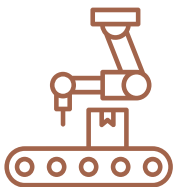

UK manufacturing excellence with reliable delivery



A global network of distribution partners in 50+ countries



Sustainability focused – committed to reducing environmental impact



Expert support from design stage to installation

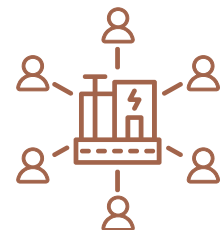

Six decades of experience protecting infrastructure and people

OUR PLEDGE TO YOU

At Ellis, our customers are at the heart of everything we do. As Managing Director, I want to personally reaffirm the commitment that guides every decision we make and every product we deliver.

Our pledge to you;



Unrivalled customer service

We will provide an exceptional customer experience at every stage of your journey with us. Your challenges will be met with responsiveness, clarity and genuine care.

Technical excellence

We will continue to apply the highest levels of knowledge, engineering expertise and innovation to every solution we design and manufacture. You can trust that our products are built on a foundation of proven technical performance.

Integrity and trust

We will act with honesty, transparency and accountability in all our interactions. We will always do the right thing – especially when no one is watching.

Quality without compromise

We will deliver products you can rely on. Every item we manufacture meets stringent quality standards so you can install and operate with confidence.

A partnership approach

We will work with you, not just for you. Our focus is on building long-term relationships where your success is our success. We aim to be the solution provider and trusted partner you can depend on.

Our commitment

Guided by our mission 'to design, manufacture and deliver innovative and quality products, through knowledge, expertise and trust' and driven by our vision to be 'the solution provider and trusted partner in the industries we serve', this pledge represents our promise – today and for the future.

Thank you for choosing Ellis

A handwritten signature in black ink, reading 'Danny Macfarlane'. The signature is stylized and fluid, with a large initial 'D' and 'M'.

Danny Macfarlane
Managing Director

OUR SECTORS

 Data Centres

 Transmission & Distribution

 Renewables

 Power Generation

 Oil & Gas

 Transportation

 Infrastructure

 Mining





HERCULES HEAVY DUTY NON-METALLIC CABLE HANGER



Hangers shown in a typical concrete trough installation

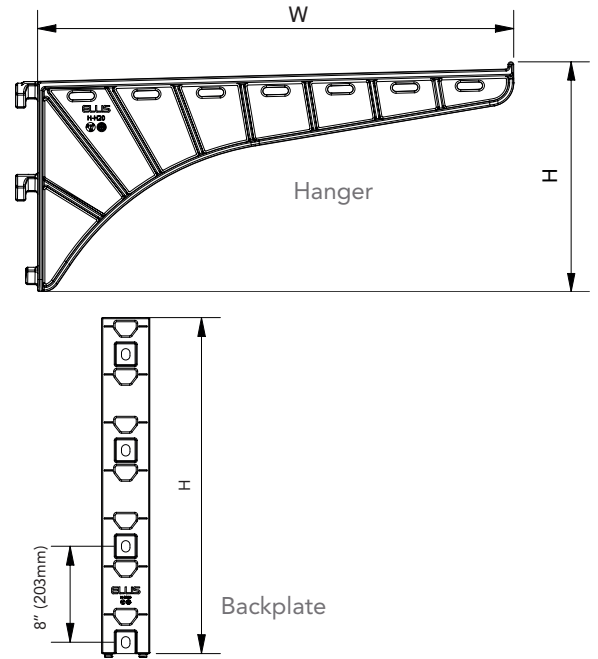

- GRP cable hanger system
- Will not rust or corrode
- Insulating hanger with excellent dielectric properties; no earth bonding or grounding required
- Multiple combinations of hangers available
- Manufactured from UL listed heavy duty glass reinforced polymer
- Resistant to UV and suitable for long term installation in areas exposed to sunlight
- Backplates can be installed in tandem and slot into each other to achieve the required backplate height
- Hangers slot into the backplate allowing the backplate to be installed first and hangers added later as required
- A keeper to lock the hangers in place is included with every hanger

PART NO.	DESCRIPTION	DIMENSIONS		WEIGHT*		RATED DISTRIBUTED LOAD (N)	DEFLECTION (MM)	FIXINGS REQUIRED
		W	H	Lbs	Kg			
H-H06-UV	6" Hanger	6" (165mm)	5.6" (143mm)	1.0	0.43	TBC	TBC	-
H-H10-UV	10" Hanger	10" (254mm)	5.7" (145mm)	1.3	0.60	TBC	TBC	-
H-H14-UV	14" Hanger	14" (360mm)	6.7" (170mm)	1.9	0.87	TBC	TBC	-
H-H20-UV	20" Hanger	20" (521mm)	9.8" (251mm)	3.2	1.46	TBC	TBC	-
H-H25-UV	25" Hanger	25" (635mm)	10.8" (274mm)	4.1	1.84	TBC	TBC	-
H-BP12-UV	12" Backplate	-	12" (305mm)	1.2	0.54	TBC	TBC	2 X M12 or 2 x 1/2"
H-BP28-UV	28" Backplate	-	28" (711mm)	2.8	1.25	TBC	TBC	4 X M12 or 2 x 1/2"
H-BP36-UV	36" Backplate	-	36" (914mm)	3.5	1.60	TBC	TBC	5 X M12 or 2 x 1/2"

*Weights are estimated, subject to confirmation, details will be confirmed on order placement



PEGASUS® COMPOSITE CABLE HANGER SYSTEM



LUL 1-085
Approved
Material



UV Stabilised
Material

HANGER	SWL KG
100	60
75	45
50	45
CC	25



PG050



PG075



PG100



PGCC



- Composite cable hanger system: polymer hanger and fully enclosed corrosion resistant aluminium spine
- Up to 50% lighter than conventional steel system, improves installation time by reducing installer fatigue
- Will not rust or corrode
- Insulating hanger with excellent dielectric properties; no earth bonding or grounding required
- Curved profile hanger design allows natural cable sag
- Multiple combinations of hangers available; curved configuration to suit tunnel walls also available
- Available in LUL 1-085 material for indoor applications or UV stabilised material for external applications
- Impulse tested to 30kV
- Listed for use on the London Underground Product Register: product ID 315

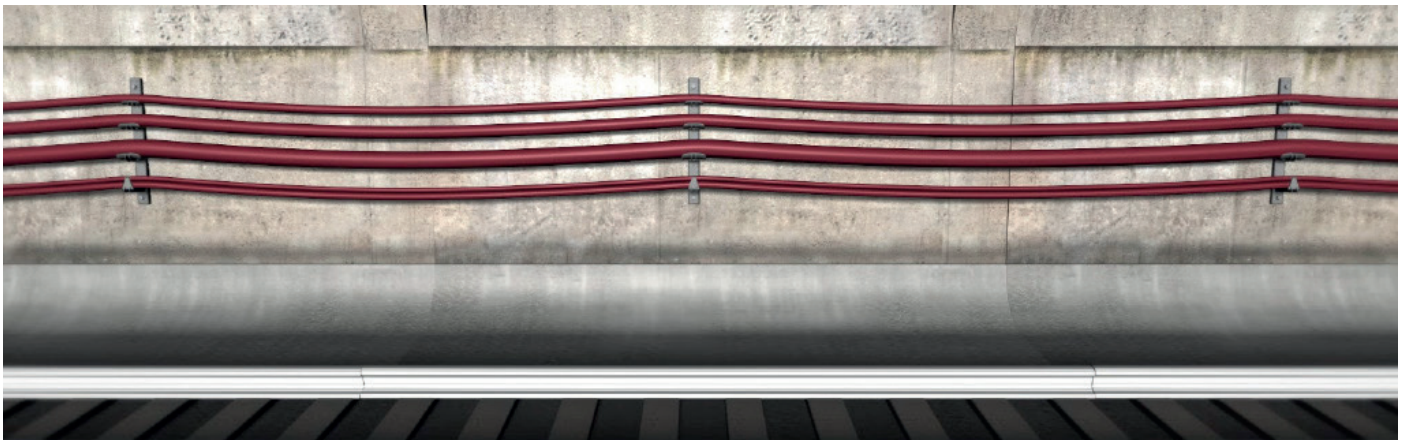

* Load Capacity: Brackets with multiple hook configurations are designed to operate with all hooks carrying their maximum load. Dimensions are provided with a tolerance, refer to the detailed drawings for details.

PART NO.	WAYS	DIMENSIONS (MM)							FIXING HOLES	UV WEIGHT (KG)	LUL WEIGHT (KG)	SWL KG
		A	B	C	D	E	F	G				
PG050-1	1	197	119	-	46	92	Ø50	-	2 x M12	0.3	0.38	45
PG050-2	2	276	198	79	46	92	Ø50	-	2 x M12	0.45	0.57	90
PG050-3	3	356	277	79	46	92	Ø50	-	2 x M12	0.61	0.76	135
PG050-4	4	435	357	79	46	92	Ø50	-	2 x M12	0.76	0.95	180
PG050-5	5	514	436	79	46	92	Ø50	-	2 x M12	0.92	1.14	225
PG050-6	6	594	515	79	46	92	Ø50	-	2 x M12	1.07	1.33	270
PG075-1	1	238	159	-	58	108	Ø75	-	2 x M12	0.39	0.49	45
PG075-2	2	358	280	120	58	108	Ø75	-	2 x M12	0.64	0.79	90
PG075-3	3	478	400	120	58	108	Ø75	-	2 x M12	0.88	1.09	135
PG075-4	4	598	520	120	58	108	Ø75	-	2 x M12	1.13	1.39	180
PG075-5	5	718	640	120	58	108	Ø75	-	2 x M12	1.37	1.69	225
PG075-6*	6	838	760*	120	58	108	Ø75	-	2 x M12	1.62	1.99	270
PG075-3.SPH-1.075-3	6	917	839	120	58	108	Ø75	415	3 x M12	1.95#	2.15	270
PG100-1	1	280	202	-	71	122	Ø100	-	2 x M12	0.48	0.6	60
PG100-2	2	442	364	162	71	122	Ø100	-	2 x M12	0.82	1.01	120
PG100-3	3	604	526	162	71	122	Ø100	-	2 x M12	1.16	1.42	180
PG100-4	4	766	688	162	71	122	Ø100	-	2 x M12	1.49	1.83	240
PG100-5*	5	928	850*	162	71	122	Ø100	-	2 x M12	1.83	2.24	300
PG100-6*	6	1090	1012*	162	71	122	Ø100	-	2 x M12	2.16	2.65	360
PG100-2.SPH-1.100-3	5	1007	928	162	71	122	Ø100	379	3 x M12	2.27#	2.50	300
PG100-3.SPH-1.100-3	6	1169	1091	162	71	122	Ø100	541	3 x M12	2.67#	2.94	360
PGCC-1	1	279	200	-	55	57	107	-	2 x M12	0.43	0.55	25
PGCC-2	2	440	361	161	55	57	107	-	2 x M12	0.72	0.9	50
PGCC-3	3	601	522	161	55	57	107	-	2 x M12	1	1.26	75
PGCC-4	4	762	683	161	55	57	107	-	2 x M12	1.29	1.62	100
PGCC-5*	5	923	844*	161	55	57	107	-	2 x M12	1.57	1.97	125
PGCC-6*	6	1084	1005*	161	55	57	107	-	2 x M12	1.86	2.33	150
PGCC-2.SPH-1.CC-3	5	1002	923	161	55	57	107	377	3 x M12	1.93#	2.13	125
PGCC-3.SPH-1.CC-3	6	1163	1084	161	55	57	107	538	3 x M12	2.26#	2.47	150

*If hole spacing exceeds 750mm, Ellis recommends using the configuration with an additional fixing
#Calculated weights

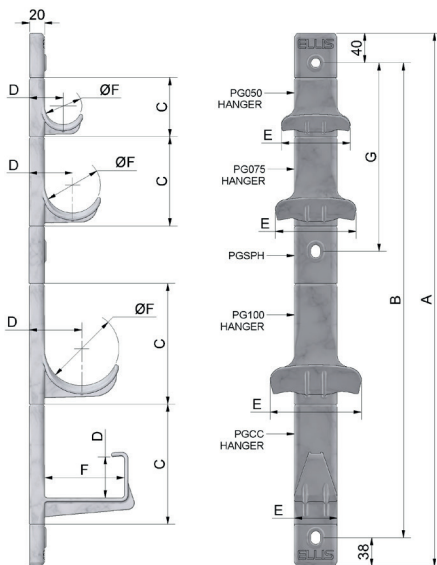

Pegasus is a fully assembled modular system, available in any configuration

Part Numbers for special configurations can be worked out as follows:

- Example: Part Number for product shown would be: PG 50-1/75-1/100-1/CC-1
- PG defines the product as Pegasus
- The size and number of hangers is then listed as shown, starting from the top
- Any number of hangers can be specified in any order
- Standard material is suitable for tunnel applications, for UV stabilised material add -UV to part#
- Standard product is straight but can be supplied curved, for curved option add -C to end of part
- For a detailed drawing with dimensions, refer to Ellis Drawing 7294



PEGASUS[®] RETROFIT CABLE HANGERS



120mm Hanger



Installation on London Underground

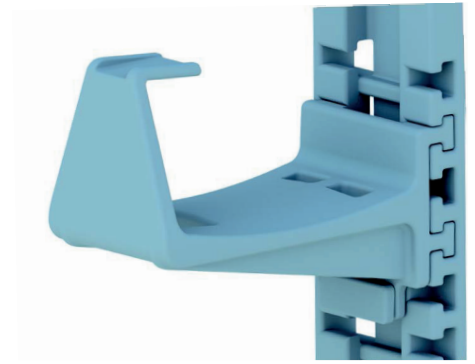
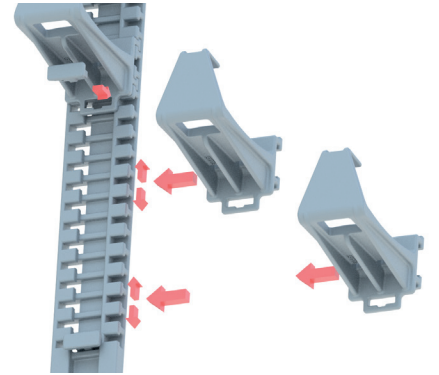

The hangers slide into the backplate and are held in position by a removable keeper. The design allows for fine adjustment of the hanger position to suit the location of the installed cable.

- Lightweight hanger system designed to be retrofit in existing cable installations.
- Low profile design allows hanger to be slid in behind existing cables without disturbing existing hangers
- Polymer material will not rust or corrode
- Insulating hanger with excellent dielectric properties; no earth bonding or grounding required
- Adjustable hanger position in 20mm increments
- Available with short (120mm) or long hangers (150mm)
- Available in LUL 1-085 material for indoor applications or UV stabilised material for external applications
- Slide in hangers and keepers allow rapid installation
- Safe working load 20kg per hanger

Two hanger lengths available: (120mm & 150mm)

Two material options: Indoor - LUL 1-085
Outdoor - UV RESISTANT

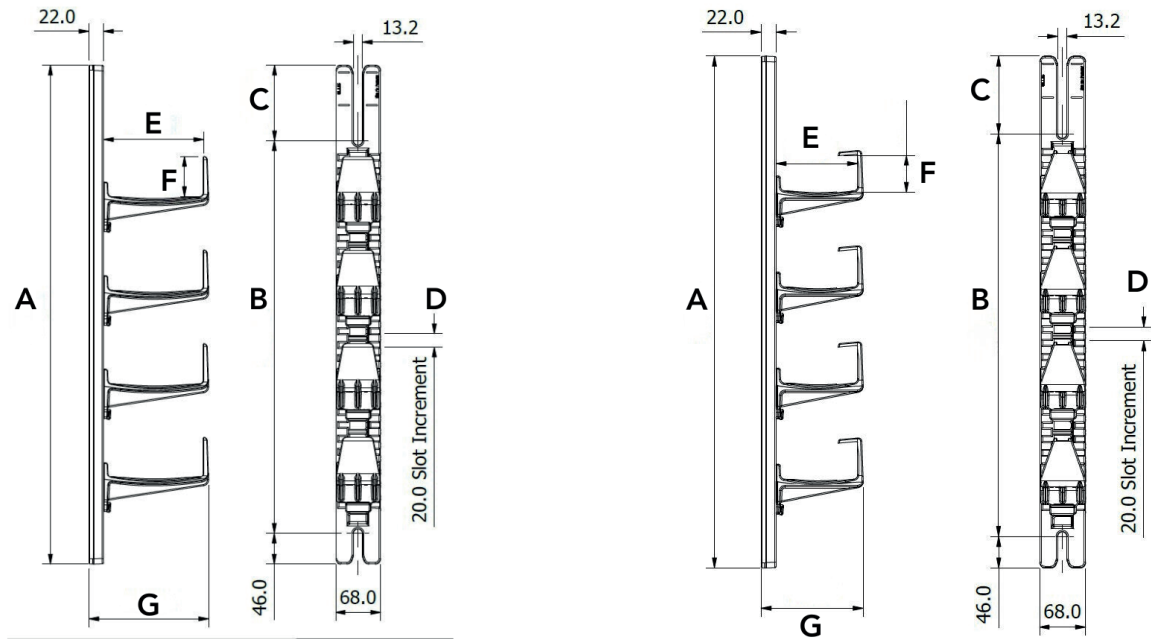

PART NO.	DESCRIPTION	DIMENSIONS (MM)							LUL WEIGHT (G)	UV WEIGHT (G)
		A	B	C	D	E	F	G		
SFPG-BKPL748-XX	RETROFIT BACKPLATE	748	589	113	20	-	-	-	960	815
SFPG-CC01-XX	CC01 HANGER (120mm) & KEEPER	-	-	-	-	120	54.6	150.2	260	230
SFPG-CC02-XX	CC02 HANGER (150mm) & KEEPER	-	-	-	-	143	60	180	295	250

The part numbers listed above cover both material options.

For indoor applications, where LUL 1-085 material is required, remove the -XX from the part number above.

For outdoor applications, where UV resistant material is required, replace the -XX in the part number above with -UV



PEGASUS[®] MULTI-FIX CABLE HANGERS



120mm Hanger

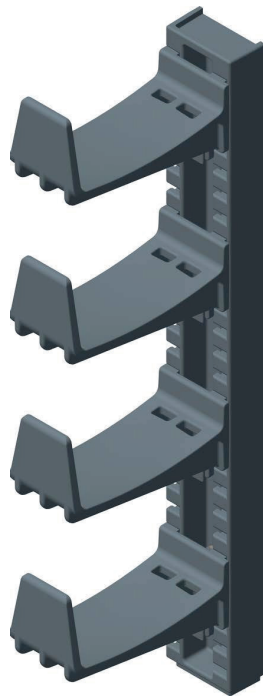

150mm Hanger



Post Hanger Installation

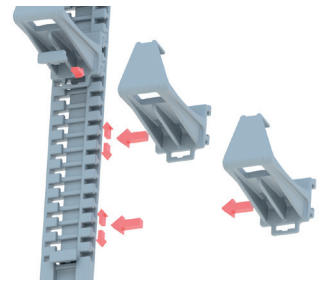

The hangers slide into the backplate and are held in position by a removable keeper.

The design allows for fine adjustment of the hanger position to suit the location of the installed cable.

- Hanger system designed to be affixed to posts or walls
- Low profile design allows the hanger to be slid in behind existing cables without disturbing existing hangers
- Polymer material will not rust or corrode
- Insulating hanger with excellent dielectric properties; no earth bonding or grounding required
- Adjustable hanger position in 20mm increments
- Available with short (120mm) or long hangers (150mm)
- Available in LUL 1-085 material for indoor applications or UV stabilised material for external applications
- Slide in hangers and keepers allow rapid installation
- SWL 20kg per hanger

Two hanger lengths available: (120mm & 150mm)

Two material options: Indoor - LUL 1-085
Outdoor - UV RESISTANT

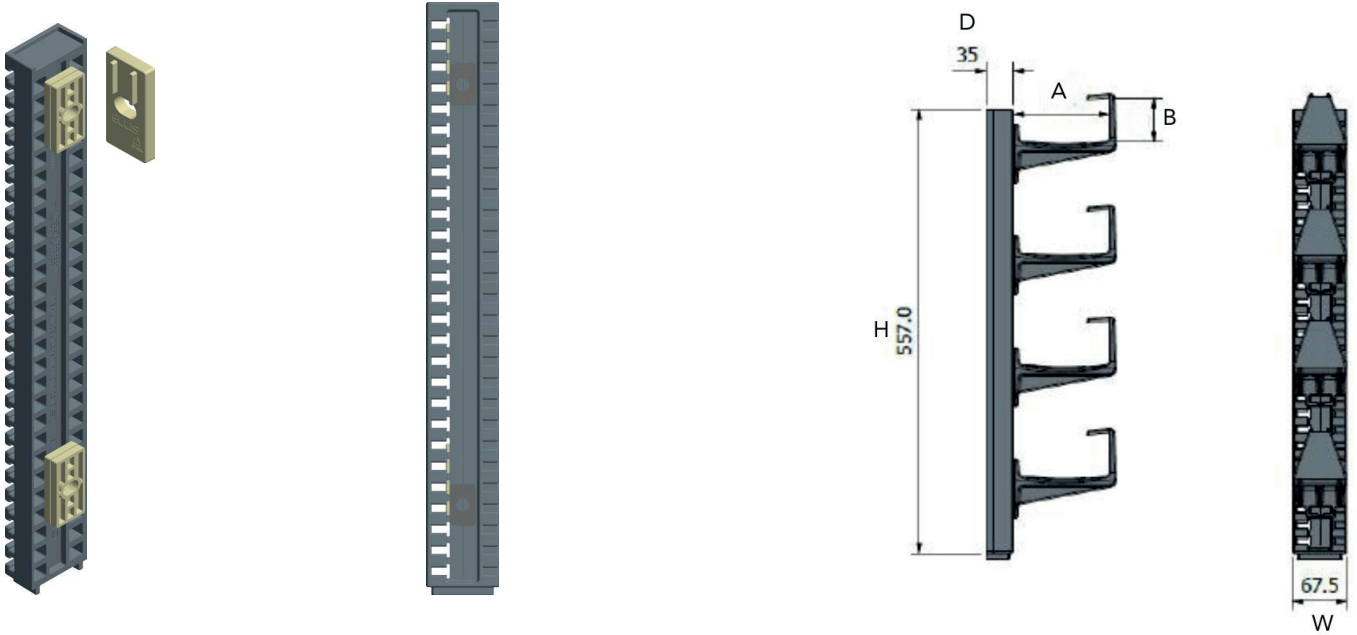

Spacers are available to space hanger correctly if it is to be mounted in a concrete post with a slot. Spacers are 8mm thick and can be stacked. See part numbers at bottom of page.

Backplates are supplied undrilled and are required to be drilled on assembly dependant on fixing. Stainless Steel washers are required to spread the load over the backplate. Fixings are M12 and minimum two are required.

PART NO.	DESCRIPTION	DIMENSIONS (MM)					LUL WEIGHT (G)	UV WEIGHT (G)
		H	W	D	A	B		
PFPG-BKPL565-XX	MULTI-FIX BACKPLATE	557	67.5	35	-	-	790	790
PFPG-SPC01-XX	BACKPLATE SPACER	-	-	-	-	-	19	19
OF-PFPG-WASHER-01-4	BACKPLATE WASHER (Stainless Steel)	-	-	-	-	-	-	-
SFPG-CC01-XX	CC01 HANGER (120mm) & KEEPER				120	54.6	260	230
SFPG-CC02-XX	CC02 HANGER (150mm) & KEEPER	-	-	-	143	60	295	250

The part numbers listed above cover both material options.

For indoor applications, where LUL 1-085 material is required, remove the -XX from the part number above.

For outdoor applications, where UV resistant material is required, replace the -XX in the part number above with -UV



CONVEX CABLE HANGERS

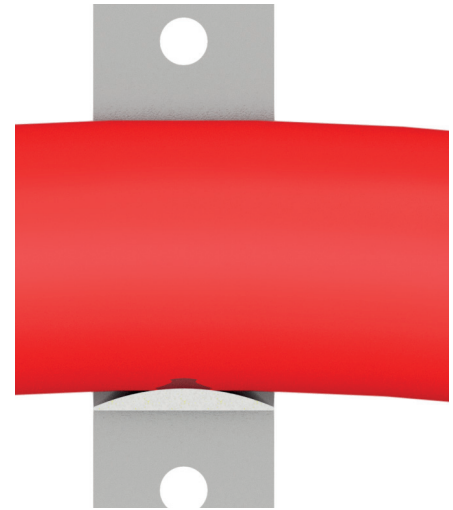
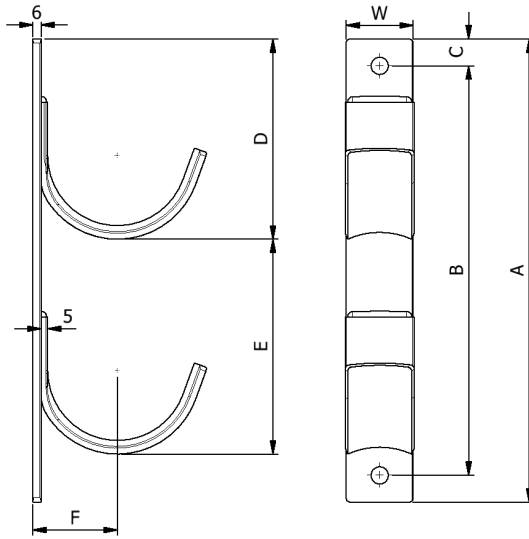

Convex cable hanger profile is kinder to the cable

- Rounded corners reduce snagging points
- Convex cable hanger profile reduces the risk of cable damage and facilitates cable sag
- Spin galvanised (55micron) to BS EN ISO 1461
- Wide range of sizes available
- Custom designs available
- Curved back plate to suit tunnel walls available
- Same strength as MK2 hanger but reduced 5mm thick hanger (backplate 6mm)
- Bespoke designs and configurations can be offered

PART NO.	CABLE Ø (MM)	NO. OF HOOKS	DIMENSIONS (MM)							FIXING HOLES	WEIGHT (G)	SWL (KG)
			A	B	C	D	E	F	W			
CH1W1	Up to 50	1	145	105	20	105	n/a	37	40	11	490	200
CH2W1	Up to 50	2	235	195	20	105	90	37	40	11	890	200
CH3W1	Up to 50	3	325	285	20	105	90	37	40	11	1270	200
CH4W1	Up to 50	4	415	375	20	105	90	37	40	11	1670	200
CH5W1	Up to 50	5	505	465	20	105	90	37	40	11	2070	200
CH6W1	Up to 50	6	595	555	20	105	90	37	40	11	2460	200
CH1W2	51-75	1	170	130	20	130	n/a	50	50	13	750	250
CH2W2	51-75	2	295	255	20	130	125	50	50	13	1390	250
CH3W2	51-75	3	420	380	20	130	125	50	50	13	2050	250
CH4W2	51-75	4	545	505	20	130	125	50	50	13	2690	250
CH5W2	51-75	5	670	630	20	130	125	50	50	13	3340	250
CH6W2	51-75	6	795	755	20	130	125	50	50	13	3990	250
CH1W3	76-100	1	185	145	20	145	n/a	62	50	13	870	250
CH2W3	76-100	2	345	305	20	145	160	62	50	13	1670	250
CH3W3	76-100	3	505	465	20	145	160	62	50	13	2490	250
CH4W3	76-100	4	665	625	20	145	160	62	50	13	3290	250
CH5W3	76-100	5	825	785	20	145	160	62	50	13	4100	250
CH6W3	76-100	6	985	945	20	145	160	62	50	13	4900	250

* Load Capacity: Brackets with multiple hook configurations are designed to operate with all hooks carrying their maximum load. As standard, parts are spin galvanised to BS EN 1461 (55microns), thicker galvanising options are available on request. Dimensions are provided with a tolerance, refer to detailed drawings for details.



SUSPENSION HOOKS



TYPE A



TYPE B



TYPE C

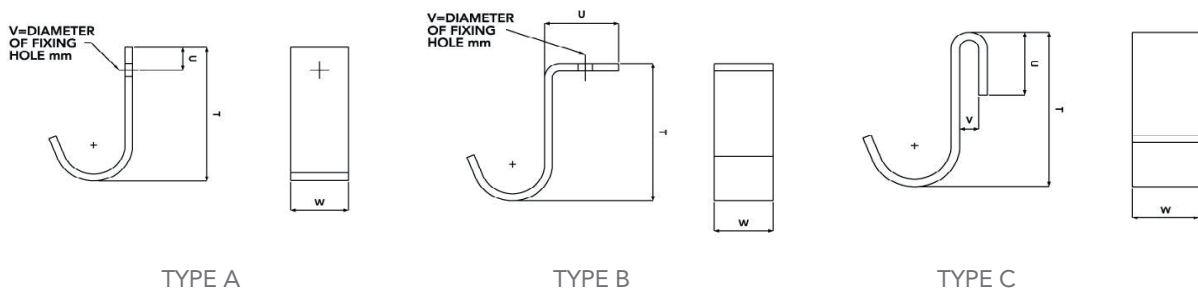

TYPE A

TYPE B

TYPE C

- Manufactured in mild steel.
- Hot dipped galvanised after manufacture.
- Special designs available on request.
- Used to hang cables on walls or support structures.

TYPE	PART NO.	MAX CABLE DIAMETER (MM)	DIMENSIONS (MM)			MATERIAL (SIZE)		PACK QTY	WEIGHT (G)	SWL (KGS)
			T	U	V	W	THICKNESS			
TYPE A	SHA1	50	105	25	11	40	6	1	320	200
	SHA2	75	120	25	13	50	6	1	490	250
	SHA3	100	155	25	13	50	6	1	1300	250
TYPE B	SHB1	50	125	55	11	40	6	1	440	200
	SHB2	75	140	60	13	50	6	1	680	250
	SHB3	100	150	60	13	50	6	1	780	250
TYPE C	SHC1	50	125	40	13	40	6	1	460	200
	SHC2	75	140	45	13	50	6	1	700	250
	SHC3	100	150	45	13	50	6	1	780	250



GRP POST FIX PEGASUS SYSTEM

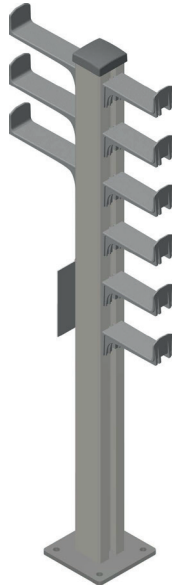
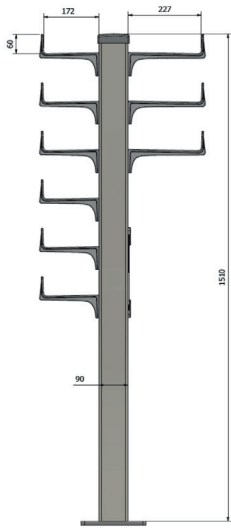

Bolt down base

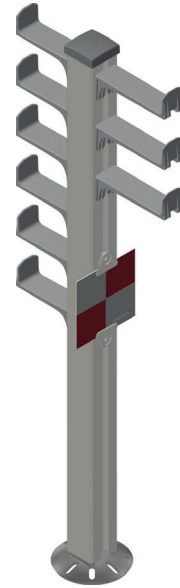

Base to suit ground anchor

- Polymer post and hanger system
- Lightweight alternative to steel systems
- Polymer material will not rust or corrode
- Insulating hanger with excellent dielectric properties, no earth bonding or grounding required
- Available with 170mm or 225mm hangers
- UV stabilised for external applications
- SWL 20kg per hanger

PART NO.	DESCRIPTION	DIMENSIONS (MM)			MATERIAL	WEIGHT (G)
		HEIGHT	WIDTH	DEPTH		
	T-SLOT GRP 2 SIDED POST	VARIOUS	90	90	GRP	-
GRPH-170CC-UV	170MM HANGER (UV)	172	70	60	UV RESISTANT	298
GRPH-225CC-UV	225MM HANGER (UV)	227	70	60	UV RESISTANT	369
PFP-CAP-B	POST SAFETY CAP	27	97.1	97.1	POLYPROPYLENE	5

WORLDWIDE DISTRIBUTION



Ellis Patents are connected to a global distribution network, so wherever you are in the world there will be one of our distributors on hand to supply the latest Ellis cable cleats and cable management support.

To find a distributor nearest to you visit
www.ellispatents.co.uk/contact/distributors

Scan to find local
distributors



ELLIS

Holding Power

Ellis Patents Ltd
High Street,
Rillington, Malton,
North Yorkshire
YO17 8LA
United Kingdom

T +44 (0)1944 758 395
sales@ellispatents.co.uk
www.ellispatents.co.uk