

# ELLIS

Holding Power

## CABLE CLEATS

TRIED. TESTED. TRUSTED.  
WORLDWIDE





---

## LEADING THE WAY

We don't just manufacture cable cleats – we *invent*, *refine*, and *set new standards* for them. With decades of engineering excellence and a portfolio of international patents, we're the trusted name in cable cleat innovation.

Our cable cleats are born from *in-house expertise*, *rigorous testing*, and *close collaboration* with global industries. From oil and gas to renewables, rail, and utilities, our products ensure safety, reliability, and performance where it matters most.

We're recognised as the *original innovator* in the modern cleat industry – introducing many of the designs and patented features now widely used, proving our role as the manufacturer others follow.

Choosing Ellis means working with the *engineers who design the solutions*, not just supply them. It means that your project benefits from cleats that are patented, proven, and trusted worldwide – inspiring complete confidence.

## AT A GLANCE

We are a global leader in the design and manufacture of safety-critical cleats, with over 60 years of innovation and engineering expertise at our heart.

At Ellis, technical excellence means pushing beyond perceived limitations in cable cleat design and performance. We don't simply meet the requirements of IEC 61914; we challenge them through rigorous testing, engineering insight and real-world application. By taking a holistic approach to cleat specification, we consider the full range of environmental, mechanical and operational pressures that installations may face over their lifetime. This commitment allows us to deliver cable cleat solutions that provide proven restraint, long-term reliability and enhanced safety, even in the most demanding conditions.



Global leader in cable cleat innovation and safety



Trusted worldwide across energy, utilities, oil & gas, rail and renewables



Proven performance – rigorously tested to international standards



Consistently achieving the highest standards of ISO accreditation



Bespoke solutions to meet project-specific needs

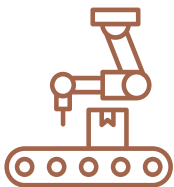

UK manufacturing excellence with reliable delivery



A global network of distribution partners in 50+ countries



Sustainability focused – committed to reducing environmental impact



Expert support from design stage to installation

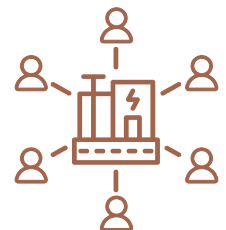

Six decades of experience protecting infrastructure and people

---

## OUR PLEDGE TO YOU

At Ellis, our customers are at the heart of everything we do. As Managing Director, I want to personally reaffirm the commitment that guides every decision we make and every product we deliver.

### Our pledge to you;



#### Unrivalled customer service

We will provide an exceptional customer experience at every stage of your journey with us. Your challenges will be met with responsiveness, clarity and genuine care.

#### Technical excellence

We will continue to apply the highest levels of knowledge, engineering expertise and innovation to every solution we design and manufacture. You can trust that our products are built on a foundation of proven technical performance.

#### Integrity and trust

We will act with honesty, transparency and accountability in all our interactions. We will always do the right thing – especially when no one is watching.

#### Quality without compromise

We will deliver products you can rely on. Every item we manufacture meets stringent quality standards so you can install and operate with confidence.

#### A partnership approach

We will work with you, not just for you. Our focus is on building long-term relationships where your success is our success. We aim to be the solution provider and trusted partner you can depend on.

#### Our commitment

Guided by our mission 'to design, manufacture and deliver innovative and quality products, through knowledge, expertise and trust' and driven by our vision to be 'the solution provider and trusted partner in the industries we serve', this pledge represents our promise – today and for the future.

Thank you for choosing Ellis

A handwritten signature in black ink that reads "Danny Macfarlane". The signature is stylized and fluid, with a large initial 'D' and 'M'.

**Danny Macfarlane**  
Managing Director

# OUR SECTORS

 Data Centres

 Transmission & Distribution

 Renewables

 Power Generation

 Oil & Gas

 Transportation

 Infrastructure

 Mining



# WORLDWIDE DISTRIBUTION



Ellis Patents are connected to a global distribution network, so wherever you are in the world there will be one of our distributors on hand to supply the latest Ellis cable cleats and cable management support.

To find a distributor nearest to you visit  
[www.ellispatents.co.uk/contact/distributors](http://www.ellispatents.co.uk/contact/distributors)

Scan to find local  
distributors



# NAVIGATING THIS BROCHURE

## General

Leading the way	3
At a glance	4
Our pledge to you	5
Our sectors	6
Worldwide distribution	7
Contents	8
Quick selection guide	9
Why we are different	10
Our products	11
What is a short circuit	12
Technical: IEC 61914	13
Specifying the correct cleat	14
Product datasheets	16 – 94
Knowledge Vault	
Sustainability	96
Accreditations & memberships	97
IEC 61914 Testing process	98
Testing for thermal expansion	100
Case studies	101
Notes	102

### KNOWLEDGE VAULT

Need more technical detail?  
Go to our Knowledge Vault section on page 96

## Products

### SINGLE & MULTICORE CABLE FORMATION 16

<b>Stainless steel</b>	
Vulcan+™	18
Vulcan+™ – Twist-Foot	20
Emperor™ Single	22
Emperor™ Single – Twist-Foot	24
Phoenix®	26

<b>Galvanised steel</b>	
Atlas™	28

<b>Aluminium</b>	
1A One Hole Cable Clamp	30
2A Two Hole Cable Clamp	32
Centaur® Single	34
Centaur® Intermediate Strap	36
Centaur® Termination Clamp	38

<b>Polymer</b>	
1F One Hole Clamp	40
2F+ Two Hole Clamp	42
Solus™ Clamp	44
No Bolts Cleat™	46
Cable Guide Clamp™	48

### TREFOIL CABLE FORMATION 50

<b>Stainless steel</b>	
Vulcan+™	52
Vulcan+™ Twist-Foot	54
Emperor™ Trefoil	56
Emperor™ Trefoil Twist-Foot	58
Colossus™	60
Flexi-Strap™	62
Protect™	64

<b>Galvanised Steel</b>	
Atlas™	66
<b>Aluminium</b>	
Alpha™	68
Centaur® Trefoil	70
Centaur® Spaced Intermediate Strap	72

<b>Polymer</b>	
Trident®	74
Trident® with Spacer	76

### QUAD CABLE FORMATION 78

<b>Stainless steel</b>	
Vulcan+™ Quad	80
Vulcan+™ Quad Twist-Foot	82
Emperor™ Quad	84
Emperor™ Quad Twist-Foot	86

### MULTIPLE / COMPLEX CABLE FORMATION

<b>Polymer</b>	
Matrix	88

### FIXINGS AND ACCESSORIES 89

Ladder adaptors	90
Insulation Plate	91
Triplex Cable Surround	92

### HANGERS 94

## SINGLE & MULTICORE CABLE FORMATION >>

STAINLESS STEEL



Vulcan+™ Pg.18



Vulcan+™ Single Twist Foot Pg.20



Emperor™ Single Pg.22



Emperor™ Single Twist Foot Pg.24



Phoenix® Pg.26



Atlas™ Pg.28

ALUMINIUM



1A One Hole Cable Clamp Pg.30



2A Two Hole Cable Clamp Pg.32



Centaur® Single Pg.34



Centaur® Intermediate Strap Pg.36



Centaur® Termination Clamp Pg.38

POLYMER



1F One Hole Cable clamps Pg.40



2F+ Two Hole Cable clamps Pg.42



Solus Clamp™ Pg.44



No Bolts Cleat™ Pg.46



Cable Guide Clamp Pg.48

## TREFOIL CABLE FORMATION >>

STAINLESS STEEL



Vulcan+™ Pg.52



Vulcan+™ Trefoil Twist Foot Pg.54



Emperor™ Trefoil Pg.56



Emperor™ Trefoil Twist Foot Pg.58



Colossus™ Pg.60



Flexi-Strap™ Pg.62

GALVANISED STEEL



Protect™ Pg.64



Atlas™ Pg.66



Alpha™ Pg.68



Centaur™ Trefoil Pg.70



Centaur™ Spaced Intermediate Strap Pg.72

POLYMER



Trident™ Pg.74



Trident™ with Spacer Pg.76

## QUAD CABLE FORMATION >>

STAINLESS STEEL



Vulcan+™ Quad Pg.80



Vulcan+™ Quad Twist Foot Pg.82



Emperor™ Quad Pg.84



Emperor™ Quad Twist Foot Pg.86

POLYMER



Matrix™ Pg.88

## FIXINGS AND ACCESSORIES >>

Ladder Adaptors Pg.90



Insulation Plates Pg.91



Triplex Cable Surround Pg.92



# WHY WE ARE DIFFERENT

## The importance of correct cable cleating



Cable cleats secure cables and restrain movement during short-circuit faults. Correct specification and installation are critical for safety, equipment protection, and system integrity. During faults, powerful electromagnetic forces can move cables violently. Engineers and designers must ensure cable systems are properly restrained to meet standards and prevent damage, disruption, or risk to personnel.

## Standards, testing and performance



Ellis cable cleats are tested to IEC 61914, verifying strength and resistance to mechanical, environmental, and electrical stresses. Tests confirm short-circuit restraint, axial & lateral load resistance, temperature and impact performance, and flame propagation, resistance to corrosion, and UV. Short-circuit testing is the only reliable means of proving a cleat can survive fault conditions.

## Design and installation guidance



A number of factors need to be considered from environmental factors and cleat spacing to configuration and current magnitude. Material selection is important to protect against both environmental and galvanic corrosion. Other considerations include eddy currents, thermal expansion, multi-core and bundled cables, fire performance, UV resistance and thread galling.

## Product certification and documentation



Ellis provides full supporting documentation for all cleats including short circuit test certificates from independent accredited laboratories. Detailed product data sheets and installation instructions. Detail about material corrosion resistance. Engineering drawings and compliance statements. The Ellis Black Book has a checklist to use when selecting the correct cable cleats.

# OUR PRODUCTS

Ellis have been setting the benchmark for innovation from our early beginnings working with the major utilities companies to our revolutionary development of the modern cable cleat in the 1990s. We've transformed cable management, establishing the standards that continue to define safety and reliability across global industries. Today our cable management solutions include:

## Cable cleats



Our standard range of cable cleats have been developed and refined to provide critical short circuit protection in the event of a fault.

## HV solutions



We have a reputation as a leader in providing innovative solutions for the high-voltage (HV) market. Our dedication to pioneering technology and superior design has led to a portfolio of products that enhance efficiency, safety, and reliability in high-voltage applications.

## Cable hangers



Ellis cable hangers are supplied into installations where hanging cables have been selected as the cable management system as opposed to cleats. These products are covered, in detail, in our Cable Hanger Brochure.

See page 92 for an introduction to our Cable Hangers.

## Bespoke solutions



When your project demands something beyond standard cable management, Ellis have the in-house tool making and engineering expertise to be able to rapidly design, prototype, test and manufacture new products with ease.

# WHAT IS A SHORT CIRCUIT

A short circuit is an abnormal electrical condition where current flows along an unintended, low-resistance path – typically caused by insulation failure, damage, or conductor contact. This results in a sudden, very high fault current.

## Why are short circuits a problem?

When a short circuit occurs, the fault current generates extremely powerful electromagnetic forces between the conductors. These forces can be several thousand newtons per metre and act within milliseconds. If the cables are not correctly constrained nearby infrastructure or personnel can be damaged, injured, or even killed.

The picture below was taken after a controlled test event. The test demonstrates the high level of movement experienced by the unrestrained cables on the right hand side of the picture, compared to the same cable on the left hand side of the picture where the cables are correctly cleated.

## What is a cable cleat?

Cable cleats are specifically designed to:

- Restrain the cables during these short-circuit events
- Prevent cable movement, damage, or conductor separation
- Protect adjacent equipment, infrastructure, and personnel

If cleats are not correctly rated for the prospective short-circuit level, cables can whip violently, pull free, or even explode from their containment.

## What compliance standards need to be considered?

It is the responsibility of the system designer to ensure that the system is safe and will protect personnel and infrastructure in the case of a short circuit event. Ellis supply calculation and specification documents that demonstrate that the system will be safe in the event of the short circuit. To ensure compliance all Ellis cleats are designed, manufactured and tested in line with IEC 61914.



Short circuit testing  
Correctly cleated cables



Short circuit testing  
What happens when cables are not cleated (only straps were used)

# Technical: IEC 61914

We not only comply with the guidelines of IEC 61914 – we actually helped write the guidelines themselves.

Every Ellis cleat is tested to IEC 61914 as standard. Unlike other manufacturers, we go further by carrying out dynamic short-circuit testing, UV testing, and project-specific trials to guarantee real-world reliability. Our philosophy is simple: compliance is the starting point – not the finish line.

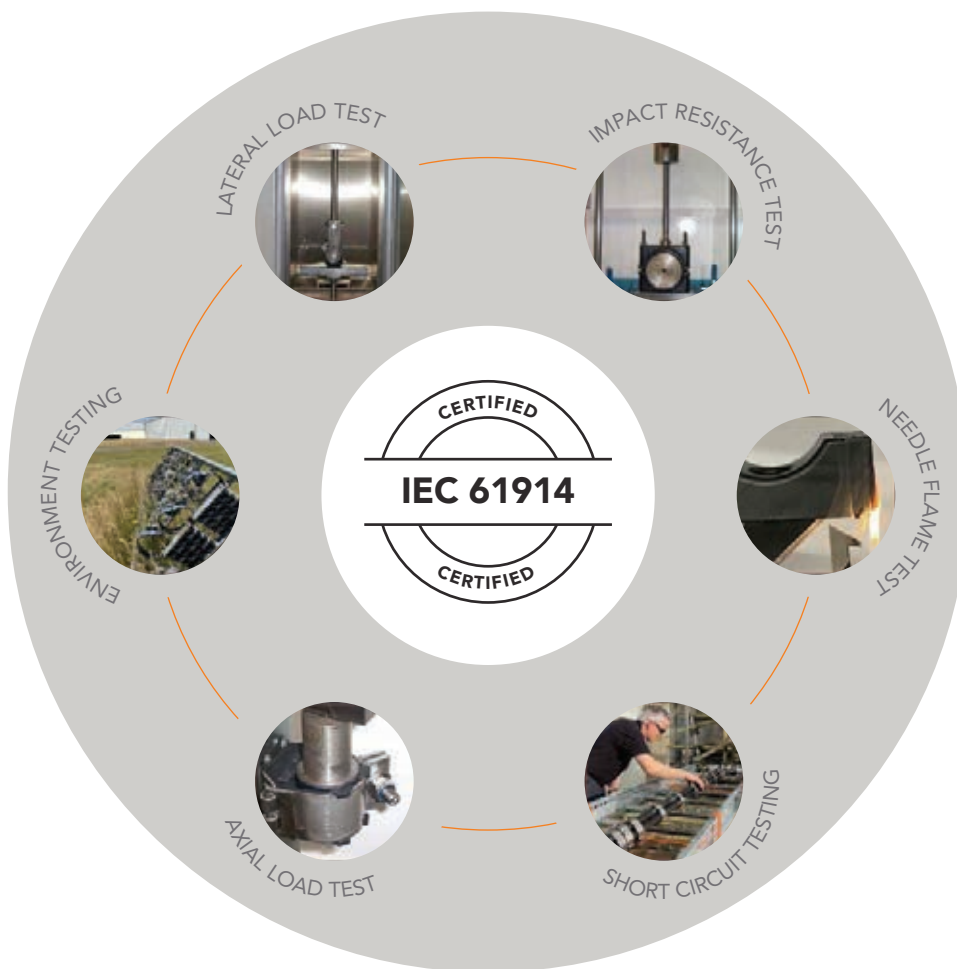

## Guaranteeing integrity

IEC 61914 defines the performance requirements and testing methods for cable cleats and intermediate restraints used to secure electrical cables. The standard ensures that cleats provide resistance to electromechanical forces and maintain system integrity under fault conditions.

## Going beyond

To achieve IEC 61914 compliance, products undergo a series of rigorous tests designed to simulate real-world installation environments. These tests generate reliable data for system designers and specifiers. We not only meet the requirements of IEC 61914 but also conduct extended testing to verify performance in conditions beyond the scope of the standard.

# SPECIFYING THE CORRECT CLEAT

Our Cleat Calculator is designed to help you select the required cable cleats for your particular project. Once all the correct specifications and environmental information is provided, the system will automatically select the correct cleats for you.

Please note, further help is always available from our highly trained technical team.

## The Ellis online Cleat Calculator

Designed to aid in the selection of cable cleats, once all the correct specifications and environmental information is provided the system will automatically select the correct cleats that are suitable for your project.



Where the system peak fault current and the cable diameter are known, the following formula, taken from The international standard IEC 61914, can be used to calculate the forces between two conductors in the event of a three phase fault:

$$F_t = \frac{0.17 \times i_p^2}{S}$$

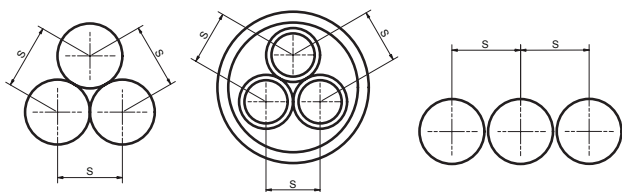

Where:

$F_t$  = force in Newton/metre (N/m)

$i_p$  = peak short-circuit current in kiloamp (kA)

$S$  = distance between the centrelines of the conductors in metres (m)

Once  $F_t$  in N/m has been determined then the force for each potential cleat can be calculated.

Metric ladder typically has rungs at 300mm intervals, so cleat spacing is usually a multiple of this distance. So,  $F_t \times 0.3$  gives the force a cleat will see if spaced at 300mm,  $F_t \times 0.6$  for 600mm etc.

$F_t \times$  cleat spacing can then be compared to the cable cleat resistance to electromechanical force and then the cleat type and spacing can be selected.

## Cable cleat resistance to electromechanical force

The values in the table are derived from actual short circuit tests carried out by Ellis. Test report numbers are detailed on individual product data sheets and test reports are available upon request. At 300mm spacing significantly more force is transmitted to the cleat by the cable compared to 600mm spacing and above.

CLEAT TYPE: TREFOIL FORMATION	CLEAT SPACING			
	300MM		600MM AND ABOVE	
	STRENGTH (N)	SC LEVEL (KA)	STRENGTH (N)	SC LEVEL (KA)
Alpha	10,306	84.7	15,992	74.5
Trident LSF	20,741	121	32,865	107.7
Trident GFN	25,438	134	25,249	94.4
Vulcan+, SD Flexi-strap	26,182	135	38,446	116
Colossus, HD Flexi-strap	42,111	170	63,750	150
Emperor, HD Flexi-strap	51,034	195	62,903	149
CLEAT TYPE: SINGLE FORMATION				
Phoenix	2,466	31.1	2,466	31.1
Vulcan+	7,436	135	18,116	149
2F+	-	-	6,561	80.2
Solus LSF	10,057	157	15,093	136
Solus GFN	10,974	164	11,555	119
Emperor+	15,198	193	18,360	150

### ALWAYS REMEMBER

Whole job cost should always be considered as costs can often be reduced by using a stronger, more expensive cleat at a wider spacing than a lower cost option at more regular intervals.

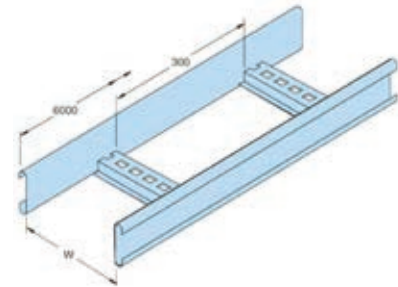

Knowing the maximum peak short circuit current, as specified by the system designer, allows the appropriate cleat and spacing to be selected. The short circuit calculation formula uses peak current, however this is often unavailable with a Root Mean Square (RMS) value given instead.

The ratio of peak to RMS short circuit fault current is dependent on the electrical characteristics of an installation, and typically specified by the system design Electrical Engineer. As standard Ellis recommends the conversion factor used is 2.5, this is taken from IEC62271: High Voltage Switchgear. Dependant on the system a lower value can be used, IEC 61439-1: Low Voltage Switchgear and Control Gear Assemblies is commonly referred to, which uses the multiples in the table below. It is acceptable to use a value other than 2.5 with input from the system Engineer.

RMS value of SC current (kA)	Multiple
$10 < I \leq 20$	2
$20 < I \leq 50$	2.1
$50 < I$	2.2

Before a cleat and spacing are finalised, two other factors should be considered irrespective of the short-circuit level,

- 1) It is strongly recommended that a system employs a fault rated cleat or restraint at a maximum spacing of 1,500mm.
- 2) On bends and risers it is recommended that the maximum cleat spacing is 300mm.
- 3) Near cable termination points, due to thermal expansion large axial forces are present. Therefore, cleats with strong axial resistance and a smaller cleat spacing is recommended to avoid damage to equipment.

# SINGLE & MULTICORE CABLE FORMATION

Ellis offers a comprehensive range of single and multicore formation cable cleats engineered to securely retain LV, MV and HV cables across demanding industrial environments. Designed to control cable movement under normal operating conditions and fault scenarios, Ellis' cable cleats provide reliable mechanical restraint for installations in energy, infrastructure, industrial and hazardous-area applications.

The range is manufactured in a variety of high-performance materials to suit specific environmental, mechanical and regulatory requirements, including stainless steel, aluminium and advanced polymer options. These materials offer proven resistance to corrosion, UV exposure, temperature extremes and chemical attack, ensuring long-term performance in both indoor and outdoor installations.

To accommodate diverse installation requirements, Ellis' cable cleats are available with multiple fixing and mounting options, enabling secure attachment to a wide range of support structures and cable management systems. Whether installed on ladder, tray, strut or bespoke steelwork, Ellis' solutions deliver consistent performance, compliance and ease of installation.

## SINGLE & MULTICORE CABLE FORMATION

<b>Stainless steel</b>	
Vulcan+™	18
Vulcan+™ Twist-Foot	20
Emperor™ Single	22
Emperor™ Single Twist-Foot	24
Phoenix®	26
<b>Galvanised steel</b>	
Atlas™	28
<b>Aluminium</b>	
1A One Hole Cable Clamp	30
2A Two Hole Cable Clamp	32
Centaur® Single	34
Centaur® Intermediate Strap	36
Centaur® Termination Clamp	38
<b>Polymer</b>	
1F One Hole Clamp	40
2F Two Hole Clamp	42
Solus™ Clamp	44
No Bolts Cleat™	46
Cable Guide Clamp™	48

The data sheets are subject to change without notice. The information provided has been generated in laboratory conditions, as such results in use may vary.







Single cable formation  
**VULCAN+™**  
 Stainless steel

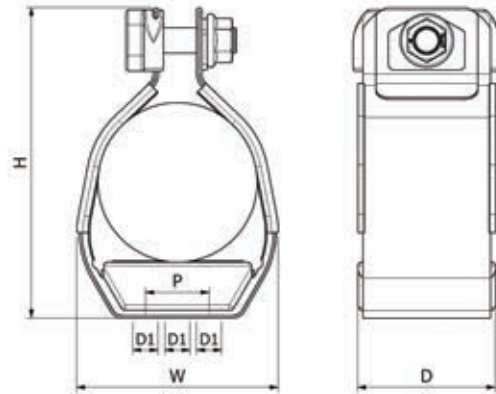

- Standard duty cable cleat for single cable formation
- Cable range of Ø18mm – Ø170mm
- 316L stainless steel frame with A4-70 stainless steel captive closure fixings
- Low Smoke and Fume Zero Halogen (LSFOH), Phosphorus Free polymeric liners for increased cable protection
- Fixing options: one or two M10 fixings (cleat size dependent, as listed in table)
- ABS and DNV type approved and UL listed
- Designed, tested and manufactured in accordance with IEC 61914

PART NO.	CABLE RANGE		DIMENSIONS (MM)					WEIGHT (G)
	MIN Ø (MM)	MAX Ø (MM)	W MAX	D ±1	H ±5	P ±0.5	FIXING HOLES (D1)	
VRT+00B	18	28	60	54	90	N/A	1 x M10	280
VRT+00A	26	30	60	54	93	N/A	1 x M10	287
VRT+00	30	42	60	54	92	N/A	1 x M10	251
VRT+01	38	50	60	54	100	N/A	1 x M10	258
VRT+02	43	58	68	54	108	N/A	1 x M10	269
VRT+03	49	64	74	54	113	N/A	1 x M10	279
VRT+04	55	70	80	54	119	N/A	1 x M10	284
VRT+05	58	75	85	54	125	N/A	1 x M10	319
VRT+06	63	84	94	54	134	N/A	1 x M10	331
VRT+07	73	90	103	54	140	N/A	1 x M10	391
VRT+08	83	100	110	54	151	N/A	1 x M10	405
VRT+09	86	104	114	54	156	N/A	1 x M10	411
VRT+10	88	110	123	54	162	50	3 x M10	442
VRT+11	90	115	125	54	168	50	3 x M10	453
VRT+12	100	125	135	54	178	50	3 x M10	460
VRT+13	107	132	146	54	185	75	3 x M10	524
VRT+14	120	145	155	54	196	75	3 x M10	536
VRT+15	125	150	160	54	202	75	3 x M10	542
VRT+16	132	153	163	54	206	75	3 x M10	544
VRT+17	136	156	172	54	212	75	3 x M10	618
VRT+18	139	159	172	54	217	75	3 x M10	628
VRT+19	142	162	172	54	222	75	3 x M10	637
VRT+20	160	170	180	54	230	75	3 x M10	646

## Testing summary

Vulcan+ Cleats have been tested in line with the International Standard 'Cable Cleats for Electrical Installations' IEC 61914. Typical results are detailed below, please note that these testing values are maximums and safety factors appropriate to your application should be used:

PROPERTY	CLASSIFICATION CLAUSE IEC 61914	UNITS / CLASSIFICATION	TEST DATA
Cleat type	6.1.3	Composite	-
Temp. for permanent application	6.2	°C	-40 to +60
UV resistance	6.5.1.2	Xenon arc method A	Pass
Corrosion resistance	6.5.2.2	High	316L Stainless steel HAS≥16% Chromium
Impact rating	6.3.4	Very heavy	Pass
Flame propagation test	10.0, 10.1	Application time ≥30s	Pass
Axial load rating	6.4.3, 9.4	Newtons (N)	110N - Single (VRT+00B = 60N)
Lateral load rating	6.4.2, 9.3	Newtons (N)	Horizontal - 200N Vertical - 650N (VRT+00B = 350N)
Resistance to electromechanical force (short circuit testing)	6.4, 6.4.5, 9.5	Cleats at 300mm intervals (withstanding more than one short circuit) single formation	135kA (Report No. PDL-22.079.04)  Cable OD= Ø36mm Phase spacing = 125mm
Resistance to electromechanical force (short circuit testing)	6.4, 6.4.5, 9.5	Cleats at 600mm intervals (withstanding more than one short circuit) single formation	149kA (Report No. LCOE 2025 09 3S 0695-3)  Cable OD= Ø35.1mm Phase spacing = 125mm



Lateral load:  
vertical direction

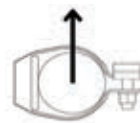

Lateral load:  
horizontal direction

Listed sizes:  
VRT+00 to  
VRT+20



Conduit & cable hardware 4CG8  
with AH-2 & wet locations. Listed  
sizes: VRT+00 to VRT+18.

LONDON UNDERGROUND  
Vulcan+ Cable Cleats are compliant with the  
requirements of LUL-1085. Product register  
number 361.



# Single cable formation VULCAN+™ TWIST FOOT

Stainless steel

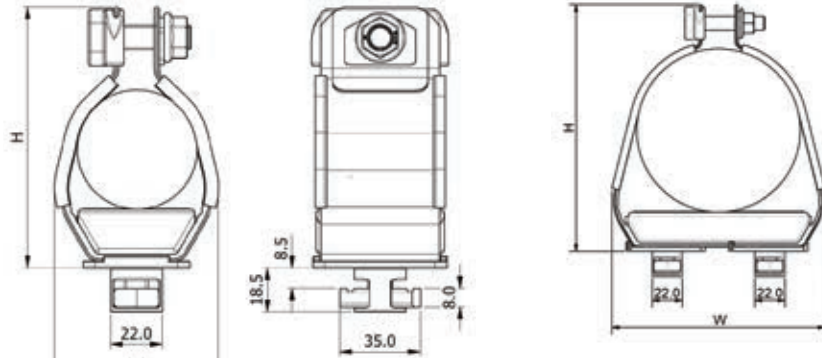

Twin fix twist foot: VRT+13 to VRT+20

- Vulcan+™ cable cleat supplied with an integrated Twist-Foot base fixing kit
- Designed for rapid installation into 41×41mm and 41×21mm unistrut channel or ladder with inverted rungs
- All fixings supplied pre-assembled – no additional site fixings required
- Standard duty cable cleat for single cable formation
- Cable range of Ø18mm – Ø170mm
- 316L stainless steel frame with A4-70 stainless steel captive closure fixings
- Low Smoke and Fume Zero Halogen (LSF0H), Phosphorus Free polymeric liners for increased cable protection
- Single-foot versions for cables up to Ø125mm
- Double-foot versions for cables Ø107mm – Ø170mm
- Fixing kits available in A4 stainless steel, galvanised steel or zinc-plated steel
- Designed, tested and manufactured in accordance with IEC 61914

PART NO.	CABLE RANGE		DIMENSIONS (MM)			WEIGHT (G)
	MIN Ø (MM)	MAX Ø (MM)	W	H	D	
VRT+00BTFM10-X	18	28	64	96	54	330
VRT+00ATFM10-X	26	30	64	96	54	337
VRT+00TFM10-X	30	42	60	96	54	301
VRT+01TFM10-X	38	50	63	102	54	308
VRT+02TFM10-X	43	58	72	109	54	319
VRT+03TFM10-X	49	64	79	115	54	329
VRT+04TFM10-X	55	70	85	121	54	334
VRT+05TFM10-X	58	75	96	128	54	369
VRT+06TFM10-X	63	84	105	137	54	381
VRT+07TFM10-X	73	90	112	143	54	441
VRT+08TFM10-X	83	100	121	152	54	455
VRT+09TFM10-X	86	104	126	158	54	461
VRT+10TFM10-X	88	110	134	166	54	492
VRT+11TFM10-X	90	115	143	174	54	503
VRT+12TFM10-X	100	125	152	181	54	510
VRT+13TTFM10-X	107	132	161	188	70	574
VRT+14TTFM10-X	120	145	169	195	70	586
VRT+15TTFM10-X	125	150	176	199	70	592
VRT+16TTFM10-X	132	153	183	208	70	594
VRT+17TTFM10-X	136	156	190	219	70	668
VRT+18TTFM10-X	139	159	200	228	70	678
VRT+19TTFM10-X	142	162	200	238	70	687
VRT+20TTFM10-X	160	170	215	243	70	696

## Testing summary

Vulcan+ Cleats have been tested in line with the International Standard 'Cable Cleats for Electrical Installations' IEC 61914. Typical results are detailed below, please note that these testing values are maximums and safety factors appropriate to your application should be used:

PROPERTY	CLASSIFICATION CLAUSE IEC 61914	UNITS / CLASSIFICATION	TEST DATA
Cleat type	6.1.3	Composite	-
Temp. For permanent application	6.2	°C	-40 to +60
UV resistance	6.5.1.2	Xenon arc method A	Pass
Corrosion resistance	6.5.2.2	High	316L stainless steel HAS≥16% chromium
Impact rating	6.3.4	Very heavy	Pass
Flame propagation test	10.0, 10.1	Application time ≥30s	Pass
Axial load rating	6.4.3, 9.4	Newtons (N)	110N (VRT+00B = 60N)
Lateral load rating	6.4.2, 9.3	Newtons (N)	Horizontal - 200N (VRT+00C = 180N)  Vertical - 650N (VRT+00B = 350N)
Resistance to electromechanical force (Short circuit testing)	6.4, 6.4.5, 9.5	Cleats at 300mm intervals (Withstanding more than one short circuit) Single formation	135kA (Report no. PDL-22.079.04)  Cable OD= Ø36mm Phase spacing = 125mm
Resistance to electromechanical force (Short circuit testing)	6.4, 6.4.5, 9.5	Cleats at 600mm intervals (Withstanding more than one short circuit) Single formation	149kA (report no. LCOE 2025 09 3s 0695-3)  Cable OD= Ø35.1mm Phase spacing = 125mm



Lateral load:  
vertical direction

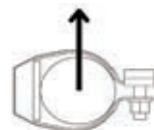

Lateral load:  
horizontal direction

X denotes fixing material, options are as follows:

4 = A4 stainless steel

G = Galvanised steel

Z = Zinc plated steel

e.g A VRT+04 with stainless steel twist foot fixings becomes:

VRT+04TFM10-4



Click to see how  
easy the Twist-Foot  
is to install.



# Single cable formation EMPEROR™ SINGLE

Stainless steel

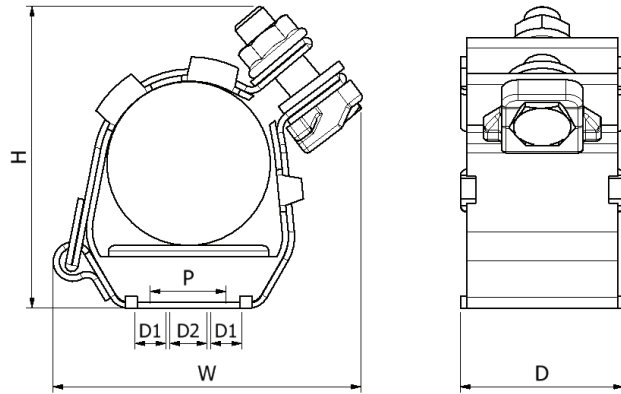

- Heavy duty cable cleat for single cable formation
- Cable range of Ø32mm – Ø150mm
- 316L stainless steel frame with A4-70 stainless steel captive closure fixings
- Low smoke and fume zero halogen (LSFOH), phosphorus free polymeric liners for increased cable protection
- Fixing options: two M10 fixings or one M12 fixing
- ABS and DNV type approved and UL listed
- Designed, tested and manufactured in accordance with IEC 61914

PART NO.	CABLE RANGE		DIMENSIONS (MM)					WEIGHT (G)
	MIN Ø (MM)	MAX Ø (MM)	W	H	D	P	FIXING HOLES (D1 & D2)	
ES32-39	32	39	91	89	54	25	2 x M10 + 1 x M12	450
ES37-45	37	45	96	93	54	25	2 x M10 + 1 x M12	470
ES44-52	44	52	99	98	54	25	2 x M10 + 1 x M12	480
ES51-59	51	59	103	102	54	25	2 x M10 + 1 x M12	490
ES58-66	58	66	109	101	54	25	2 x M10 + 1 x M12	500
ES65-73	65	73	111	103	54	25	2 x M10 + 1 x M12	510
ES73-85	73	85	135	112	54	50	2 x M10 + 1 x M12	640
ES84-94	84	94	135	135	54	50	2 x M10 + 1 x M12	660
ES94-118	94	118	160	150	54	50	2 x M10 + 1 x M12	710
ES118-130	118	130	175	160	54	75	2 x M10 + 1 x M12	900
ES127-150	127	150	180	180	54	75	2 x M10 + 1 x M12	940

## Testing summary

Emperor Cleats have been tested in line with the International Standard 'Cable Cleats for Electrical Installations' IEC 61914. Typical results are detailed below, please note that these testing values are maximums and safety factors appropriate to your application should be used:

PROPERTY	CLASSIFICATION CLAUSE IEC 61914	UNITS / CLASSIFICATION	TEST DATA
Cleat type	6.1.3	Composite	-
Temp. for permanent application	6.2	°C	-40 to +60
UV resistance	6.5.1.2	Xenon arc method A	Pass
Corrosion resistance	6.5.2.2	High	316L stainless steel has $\geq 16\%$ chromium
Impact rating	6.3.5	Very heavy	Pass
Flame propagation test	10.0, 10.1	Application time $\geq 30s$	Pass
Axial load rating	6.4.3, 9.4	Newtons (N)	250N
Lateral load rating	6.4.2, 9.3	Newtons (N)	Horizontal - 650N Vertical - 1000N
Resistance to electromechanical force (short circuit testing)	6.4, 6.4.4, 9.5	Cleats at 300mm intervals (withstanding one short circuit)	193kA (Report No. PDL-22.079.05)  Cable OD= $\varnothing 35mm$ Phase Spacing = 125mm
Resistance to electromechanical force (short circuit testing)	9.5.2, 9.5.3	Cleats at 600mm intervals (withstanding more than one short circuit)	150kA (Report No. PDL-22.159.1)  Cable OD= $\varnothing 30mm$ Phase Spacing = 125mm



Lateral load:  
vertical direction



Lateral load:  
horizontal direction



Conduit & cable hardware 4CG8 with  
AH-2 & wet locations. Listed sizes:  
ES32-39 to ES94-118.

LONDON UNDERGROUND  
Emperor Cable Cleats are compliant  
with the requirements of LUL-1085.  
Product register number 362.



Single cable formation

# EMPEROR™ SINGLE TWIST FOOT

Stainless steel

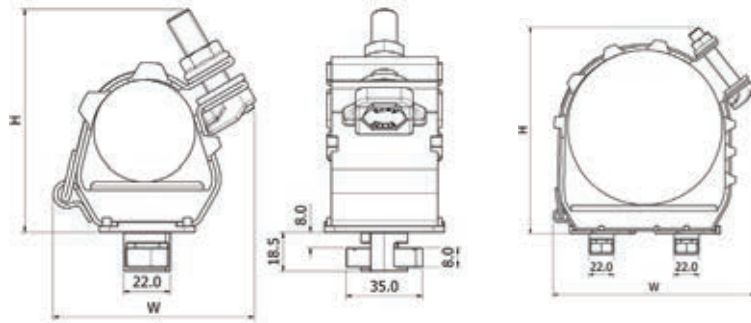

Single fix twist foot: ES32-39 to ES94-118

Twin fix twist foot: ES118-130 to 127-150

- Emperor™ single cable cleat supplied with an integrated twist-foot base fixing kit
- Designed for rapid installation into 41x41mm and 41x21mm unistrut channel or ladder with inverted rungs
- All fixings supplied pre-assembled – no additional site fixings required
- Heavy duty cable cleat for single cable formation
- Cable range of Ø32mm – Ø150mm
- 316L stainless steel frame with A4-70 stainless steel captive closure fixings
- Low smoke and fume zero halogen (LSFOH), phosphorus free polymeric liners for increased cable protection
- Single-foot versions for cables up to Ø118mm
- Double-foot versions for cables Ø118mm – Ø150mm
- Fixing kits available in A4 stainless steel, galvanised steel or zinc-plated steel
- Designed, tested and manufactured in accordance with IEC 61914

PART NO.	CABLE RANGE		DIMENSIONS (MM)			WEIGHT (G)
	MIN Ø (MM)	MAX Ø (MM)	W	H	D	
ES32-39TFM12-X	32	39	91	92	54	500
ES37-45TFM12-X	37	45	96	96	54	520
ES44-52TFM12-X	44	52	99	101	54	530
ES51-59TFM12-X	51	59	103	105	54	540
ES58-66TFM12-X	58	66	109	104	54	550
ES65-73TFM12-X	65	73	111	106	54	560
ES73-85TFM12-X	73	85	135	115	54	690
ES84-94TFM12-X	84	94	135	138	54	710
ES94-118TFM12-X	94	118	160	153	54	760
ES118-130TTFM10-X	118	130	175	163	70	1000
ES127-150TTFM10-X	127	150	180	183	70	1040

X denotes fixing material, options are as follows:

4 = A4 stainless steel

G = Galvanised steel

Z = Zinc plated steel

e.g A ES37-45 with stainless steel twist foot fixings becomes: ES37-45TFM10-4

## Testing summary

Emperor Cleats have been tested in line with the International Standard 'Cable Cleats for Electrical Installations' IEC 61914. Typical results are detailed below, please note that these testing values are maximums and safety factors appropriate to your application should be used:

PROPERTY	CLASSIFICATION CLAUSE IEC 61914	UNITS / CLASSIFICATION	TEST DATA
Cleat type	6.1.3	Composite	-
Temp. for permanent application	6.2	°C	-40 to +60
UV resistance	6.5.1.2	Xenon arc method A	Pass
Corrosion resistance	6.5.2.2	High	316L stainless steel has $\geq 16\%$ chromium
Impact rating	6.3.5	Very heavy	Pass
Flame propagation test	10.0, 10.1	Application time $\geq 30s$	Pass
Axial load rating	6.4.3, 9.4	Newtons (N)	250N
Lateral load rating	6.4.2, 9.3	Newtons (N)	Horizontal - 650N Vertical - 1000N
Resistance to electromechanical force (short circuit testing)	6.4, 6.4.4, 9.5	Cleats at 300mm intervals (withstanding one short circuit)	193kA (Report No. PDL-22.079.05)  Cable OD= $\varnothing 35mm$ Phase Spacing = 125mm
Resistance to electromechanical force (short circuit testing)	9.5.2, 9.5.3	Cleats at 600mm intervals (withstanding more than one short circuit)	150kA (Report No. PDL-22.159.1)  Cable OD= $\varnothing 30mm$ Phase Spacing = 125mm



Lateral load:  
vertical direction



Lateral load:  
horizontal direction



Click to see how  
easy the twist-foot  
is to install.



Single cable formation  
**PHOENIX<sup>®</sup>**  
 Stainless steel

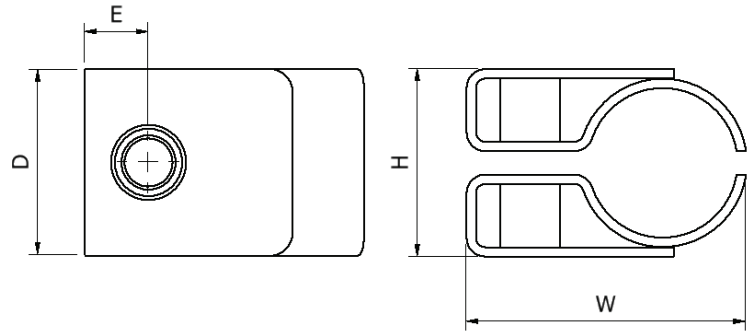

- Light duty cable clamp for single cable formation
- Specifically designed for fire protection (FP) rated cables (tested in accordance with BS 8491 and BS 5839-1)
- Cable range of Ø10mm – Ø74mm
- 316L stainless steel frame
- Fixing options: one M10 fixing
- Designed, tested and manufactured in accordance with IEC 61914

PART NO.	CABLE RANGE		DIMENSIONS (MM)					WEIGHT (G)
	MIN Ø (MM)	MAX Ø (MM)	W	H	D	E	FIXING HOLES	
1FP-10SS	10	13	40	21	40	13.7	1 x M10	91
1FP-11SS	13	16	44	24	40	13.7	1 x M10	106
1FP-12SS	16	19	47	27	40	13.7	1 x M10	113
1FP-13SS	19	23	51	31	40	13.7	1 x M10	125
1FP-14SS	23	27	55	35	40	13.7	1 x M10	139
1FP-15SS	27	32	60	40	40	13.7	1 x M10	153
1FP-16SS	32	38	66	46	40	13.7	1 x M10	174
1FP-17SS	38	46	74	54	40	13.7	1 x M10	201
1FP-18SS	46	51	80	59	40	13.7	1 x M10	225
1FP-19SS	51	57	85	64	40	13.7	1 x M10	242
1FP-20SS	57	65	93	73	40	13.7	1 x M10	265
1FP-21SS	65	74	98	82	40	13.7	1 x M10	293

## Testing summary

Phoenix Cleats have been tested in line with the International Standard 'Cable Cleats for Electrical Installations' IEC 61914. Typical results are detailed below, please note that these testing values are maximums and safety factors appropriate to your application should be used:

PROPERTY	CLASSIFICATION CLAUSE IEC 61914	UNITS / CLASSIFICATION	TEST DATA
Cleat type	6.1.1	Metallic	-
Temp. for permanent application	6.2	°C	-40 to 150+ (Fire rated)
UV resistance	6.5.1	N/A	-
Corrosion resistance	6.5.2.2	High	316L stainless steel has 16% chromium
Impact rating	6.3.4	Heavy	Pass
Flame propagation test	10.0, 10.1	No contribution to fire	Metallic
Axial load rating	6.4.3, 9.4	Newtons (N)	45N
Lateral load rating	6.4.2, 9.3	Newtons (N)	Horizontal - 350N Vertical -350N
Resistance to electromechanical force (short circuit testing)	6.4, 6.4.5, 9.5	cleats at 300mm intervals (withstanding more than one short circuit)	31kA (Report No. PDL-17.137.1)  Cable OD= Ø36mm Phase Spacing = 100mm



Lateral load:  
vertical direction



Lateral load:  
horizontal direction



Phoenix clips have been fire tested in accordance with BS 8491 and BS 5839-1.



Single cable formation  
**ATLAS™**  
 Galvanised steel

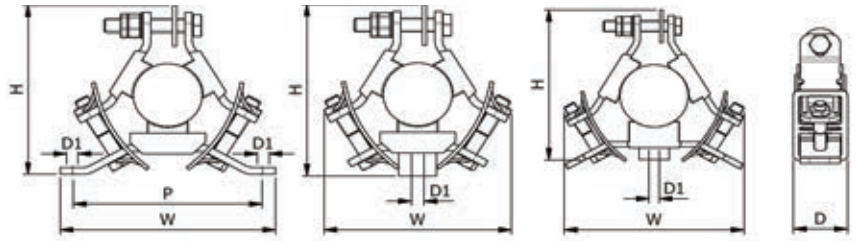

- Standard duty cable cleat for single cable formation
- Cable range of Ø38MM – Ø130MM
- Galvanised steel frame with low smoke and fume zero halogen (LSF0H), phosphorus free polymeric pads to protect the cable sheath
- Galvanised steel lower fixings and stainless steel top closure fixing to prevent eddy currents
- Fixing options: single or two bolts
- Designed, tested and manufactured in accordance with IEC 61914

PART NO.	CABLE RANGE	DIMENSIONS (MM)										WEIGHT (G)
		TWO BOLT BASE FIXING					SINGLE BOLT BASE FIXING					
		W	H	D	P	FIXING HOLES (D1)	W	H	D	FIXING HOLES (D1)		
AR2-A11-XX	38-41	170	128	54	150	2 x M10	144	136	54	1 x M10	950	
AR2-A12-XX	41-47	170	129	54	150	2 x M10	144	136	54	1 x M10	930	
AR2-A13-XX	47-55	170	140	54	150	2 x M10	157	147	54	1 x M10	940	
AR2-A14-XX	55-63	170	141	54	150	2 x M10	158	148	54	1 x M10	930	
AR3-A15-XX	63-70	198	164	54	175	2 x M10	185	172	54	1 x M10	1200	
AR3-A16-XX	70-79	198	166	54	175	2 x M10	187	173	54	1 x M10	1200	
AR4-A17-XX	79-87	224	180	54	200	2 x M10	204	188	54	1 x M12	1300	
AR4-A18-XX	87-95	224	186	54	200	2 x M10	210	193	54	1 x M12	1300	
AR4-A19-XX	95-104	224	192	54	200	2 x M10	217	199	54	1 x M12	1300	
AR5-A51-XX	104-112	250	231	54	225	2 x M10	254	231	54	1 x M12	1700	
AR5-A52-XX	112-120	250	232	54	225	2 x M10	255	232	54	1 x M12	1700	
AR5-A53-XX	120-130	250	237	54	225	2 x M10	260	237	54	1 x M12	1700	

For full part number please replace 'xx' with the following.:

TB = two bolt base fixing

SB = single bolt base fixing

## Testing summary

Atlas Cleats have been tested in line with the International Standard 'Cable Cleats for Electrical Installations' IEC61914. Typical results are detailed below, please note that these testing values are maximums and safety factors appropriate to your application should be used:

PROPERTY	CLASSIFICATION CLAUSE IEC 61914	UNITS / CLASSIFICATION	TEST DATA
Cleat type	6.1.3	Composite	-
Temp. For permanent application	6.2	°C	-40 to +60
Impact rating	6.3.5	Very heavy	Pass
Flame propagation test	10.0, 10.1	Application time $\geq 30s$	Pass
Axial load rating	6.4.3, 9.4	Newtons (N)	Refer to Ellis
Lateral load rating	6.4.2, 9.3	Newtons (N)	Refer to Ellis
Resistance to electromechanical force (Short circuit testing)	6.4, 6.4.4, 9.5	Cleats at 300mm intervals (Withstanding one short circuit)	120kA (Report no. PDL-18.122.7) Cable OD= $\varnothing 36mm$



Single cable formation

# 1A ONE HOLE CABLE CLAMP

Aluminium

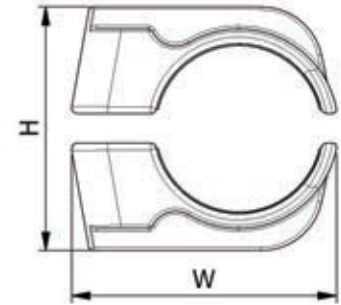
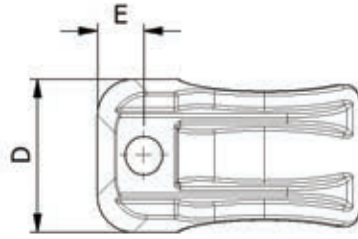

- Light duty cable clamp for single cable formation
- Cable range of Ø10mm – Ø57mm
- Cast LM6 Aluminium
- Optional epoxy coating available for harsh or corrosive environments
- Fixing options: one M10 fixing
- Fixings are not supplied as standard but are available on request
- Designed, tested and manufactured in accordance with IEC 61914

PART NO.	CABLE RANGE (MM)		DIMENSIONS (MM)				FIXING HOLES	WEIGHT (G)
	MIN	MAX	W	H	D	E		
1A-10N	10	13	37.8	27-30	41.4	10.2	1 x M10	43
1A-11N	13	16	41.2	30-33	41.4	10.4	1 x M10	52
1A-12N	16	19	44.3	33-36	41.4	10.7	1 x M10	61
1A-13N	19	23	48.2	36-40	41.4	10.9	1 x M10	68
1A-14N	23	27	52.2	40-44	41.4	11.3	1 x M10	78
1A-15N	27	32	57.1	44-49	41.4	11.6	1 x M10	85
1A-16N	32	38	63.1	49-55	41.4	12.1	1 x M10	97
1A-17N	38	46	71.3	58-66	41.4	12.9	1 x M10	121
1A-18N	46	51	77.3	67-73	41.4	13.5	1 x M10	155
1A-19N	51	57	83.2	72-78	41.4	13.9	1 x M10	171

## Testing summary

1A Clamps have been tested in line with the International Standard 'Cable Cleats for Electrical Installations' IEC 61914. Typical results are detailed below, please note that these testing values are maximums and safety factors appropriate to your application should be used:

PROPERTY	CLASSIFICATION CLAUSE IEC 61914	UNITS / CLASSIFICATION	TEST DATA
Cleat type	6.1.2	Metallic	-
Temp. For permanent application	6.2	°C	-40 to +90
Corrosion resistance	6.5.2	High	Aluminium is non-ferrous
Impact rating	6.3.5	Very heavy	Pass
Flame propagation test	10.0, 10.1	Application time $\geq 30s$	N/A
Axial load rating	6.4.3, 9.4	Newtons (N)	Refer to Ellis
Lateral load rating	6.4.2, 9.3	Newtons (N)	Refer to Ellis
Resistance to electromechanical force (Short circuit testing)	6.4, 6.4.5, 9.5	Cleats at 600mm intervals (Withstanding more than one short circuit)	70.8kA (Report no. PDL-15.025.2)  Phase spacing = 100mm Cable OD= $\varnothing 39mm$

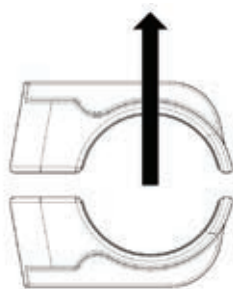

Lateral load:  
vertical direction



Lateral load:  
horizontal direction



# Single cable formation

## 2A TWO HOLE CABLE CLAMP

Aluminium

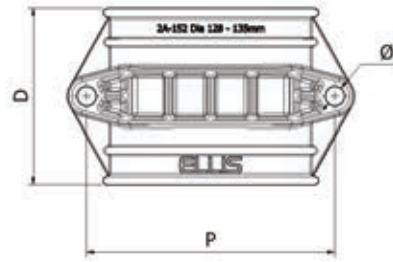
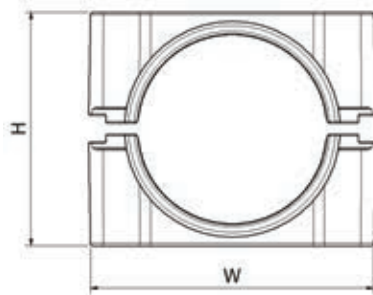

- Standard duty cable clamp for single cable formation
- Cable range of Ø32mm – Ø168mm
- Cast LM6 aluminium
- Optional Low Smoke and Fume Zero Halogen (LSF0H), Phosphorus Free polymeric liners available, for increased cable protection
- Optional epoxy coating available for harsh or corrosive environments
- Fixing options: Two fixings required, sizing shown in table below. Fixings are not supplied as standard but are available on request
- Designed, tested and manufactured in accordance with IEC 61914

PART NO.	CABLE RANGE		LINER THICKNESS (MM)	CABLE RANGE WITH LINER		DIMENSIONS (MM)					WEIGHT (G)	AXIAL LOAD	LATERAL LOAD – HORIZONTAL	LATERAL LOAD – VERTICAL
	MIN Ø (MM)	MAX Ø (MM)		MIN Ø (MM)	MIN Ø (MM)	W	H	D	P	Ø				
2A-07N	38	46	3	32	40	94	48-57	49	68	2 x M10	174	800N	12.5kN	25kN
2A-08N	46	51	3	40	45	104	54-60	49	79	2 x M10	214	800N	12.5kN	25kN
2A-09N	51	57	3	45	51	105	61-68	49	79	2 x M10	224	800N	12.5kN	25kN
2A-10N	57	64	3	51	58	105	68-76	49	79	2 x M10	234	800N	12.5kN	25kN
2A-11N	64	70	3	58	64	133	74-80	64	106	2 x M10	360	1300N	12.5kN	25kN
2A-1200N	70	76	3	64	70	133	80-87	64	106	2 x M10	376	1300N	12.5kN	25kN
2A-1201N	76	83	3	70	77	133	87-95	64	106	2 x M10	388	1300N	12.5kN	25kN
2A-1202N	83	90	3	77	84	133	94-102	64	106	2 x M10	392	1300N	12.5kN	25kN
2A-131N	90	97	4	82	89	154	101-109	76	126	2 x M10	520	1500N	12.5kN	25kN
2A-132N	97	105	4	89	97	154	109-118	76	126	2 x M10	524	1500N	12.5kN	25kN
2A-141N	105	112	4	97	104	165	118-126	76	135	2 x M10	590	1500N	12.5kN	25kN
2A-142N	112	120	4	104	112	173	124-133	76	143	2 X M10	642	1500N	12.5kN	25kN
2A-151N	120	128	5	110	118	196	148-157	125	168	2 X M12	1700	5.5kN	20kN	50kN
2A-152N	128	135	5	118	125	203	158-166	125	176	2 X M12	1840	5.5kN	20kN	50kN
2A-161N	135	144	5	125	134	222	168-178	150	190	2 X M16	2633	6kN	35kN	60kN
2A-162N	144	152	5	134	142	232	179-188	150	200	2 X M16	2856	6kN	35kN	60kN
2A-171N	152	160	5	142	150	242	190-199	150	210	2 X M16	3089	6kN	35kN	60kN
2A-172N	160	168	5	150	158	252	201-210	150	220	2 X M16	3332	6kN	35kN	60kN

For the lined version add 'L' as a suffix to the part no. E.G. '2A-07NL'.

## Testing summary

2A Clamps have been tested in line with the International Standard 'Cable Cleats for Electrical Installations' IEC 61914. Typical results are detailed below, please note that these testing values are maximums and safety factors appropriate to your application should be used:

PROPERTY	CLASSIFICATION CLAUSE IEC 61914	UNITS / CLASSIFICATION	TEST DATA
Cleat type	6.1, 6.1.3	Metallic	-
Temp. For permanent application	6.2	°C	-40 to +90
UV resistance	6.5.1.2	N/a	-
Corrosion resistance	6.5.2.2	High	Aluminium is non-ferrous
Impact rating	6.35	Very heavy	Pass
Flame propagation test	10.0, 10.1	Application time ≥30s	N/A
Axial load	6.4.3, 9.4	Newtons (N)	Refer to Ellis
Lateral load rating	6.4.2, 9.3	Newtons (N)	Refer to Ellis
Resistance to electromechanical force (Short circuit testing)	6.4, 6.4.4, 9.5	Cleats at 300mm intervals (Withstanding one short circuit)	183kA (Report no. PDL-18.071.1)  Cable OD= Ø36Mm Phase spacing = 100mm
Resistance to electromechanical force (Short circuit testing)	6.4, 6.4.5, 9.5	Cleats at 600mm intervals (Withstanding more than one short circuit)	113kA (Report no. PDL-15.025.1)  Cable OD= Ø117mm Phase spacing = 200mm

The test data provided above is for the standard version only, for test data with the liner option please contact Ellis.

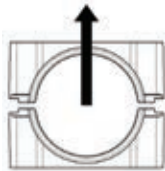

Lateral load:  
vertical direction



Lateral load:  
horizontal direction



# Single cable formation

## CENTAUR™ SINGLE

Aluminium

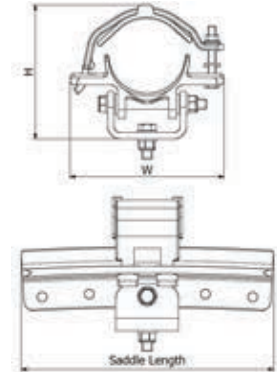

- Heavy duty cable saddle for single cable formation
- Specially designed for High Voltage, sagged cable systems
- Curved saddle accommodates cable thermal expansion and sag
- Flared edges prevent cable damage
- Cable range of Ø100mm – Ø162mm (non-standard sizes available on request)
- Available in standard lengths of 400, 600 and 800mm to allow for different cable diameters and mounting centres. Non-standard lengths available on request
- 6000 series aluminium
- A4-70 stainless steel fixings with isolation washers to prevent galvanic corrosion
- Low Smoke and Fume Zero Halogen (LSFOH), Phosphorus Free polymeric liner, incorporated into the over-strap, for increased cable protection
- Optional compatible cable rollers available
- Designed, tested and manufactured in accordance with IEC 61914

PART NO.	CABLE RANGE		DIMENSIONS (MM)			
	MIN Ø (MM)	MAX Ø (MM)	W	H	SADDLE LENGTH	BASE FIXING TYPE
CS100-112:XXX	100	112	244	205	400, 600 or 800	1 x M16
CS108-122:XXX	108	122	244	212	400, 600 or 800	1 x M16
CS120-132:XXX	120	132	244	221	400, 600 or 800	1 x M16
CS128-142:XXX	128	142	244	233	400, 600 or 800	1 x M16
CS140-152:XXX	140	152	272	240	400, 600 or 800	1 x M16
CS148-162:XXX	148	162	272	253	400, 600 or 800	1 x M16

Where ':XXX' add the saddle length required either 400, 600 or 800.

## Testing summary

Centaur cable saddles have been tested in line with the International Standard 'Cable Cleats for Electrical Installations' As IEC 61914 is part of the low voltage directive it is not possible to follow the standard exactly and thus deviations have been made in areas. Typical results are detailed below, please note that these testing values are maximums and safety factors appropriate to your application should be used:

PROPERTY	CLASSIFICATION CLAUSE IEC 61914	UNITS / CLASSIFICATION	TEST DATA
Cleat type	6.1.3	Composite	-
Temp. For permanent application	6.2	°C	-40 to +60
UV resistance	6.5.1.2	UV resistant	Metallic frame shields all polymer components.
Corrosion resistance	6.5.2.2	Refer to Ellis	-
Impact rating	6.3.5	Very heavy	Pass
Flame propagation test	10.0, 10.1	Application time ≥30s	Pass
Axial load rating	6.4.3, 9.4	Newtons (N)	Refer to Ellis
Lateral load rating	6.4.2, 9.3	Newtons (N)	Refer to Ellis
Resistance to electromechanical force (Short circuit testing)	6.4, 6.4.4, 9.5	Centaur Cleats at 8.4m with straps at midpoints	163kA (Report No. KEMA 313-08) Cable=Ø140mm

### Project specific designs:

Centaur can be adapted to suit specific project requirements, as such Ellis can alter the design to suit certain load or functionality requirements. Please contact Ellis for further details.





Single cable formation

# CENTAUR™ INTERMEDIATE STRAP

Aluminium

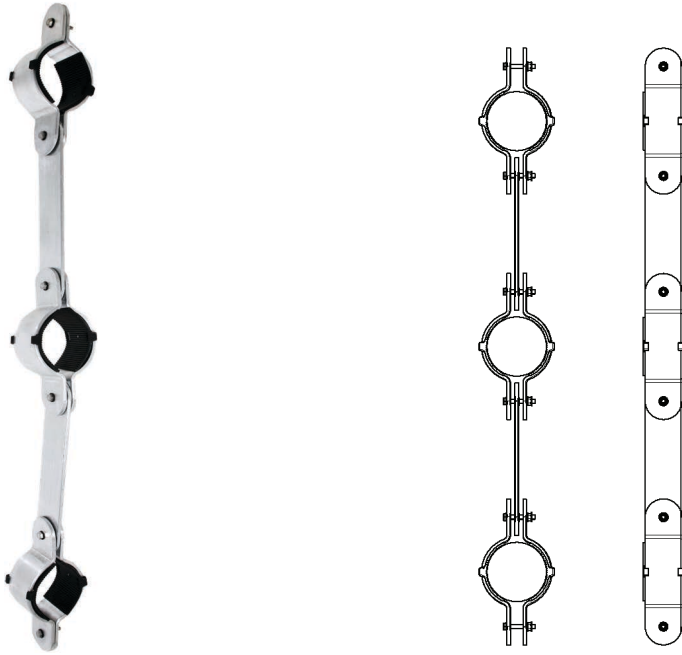

- Heavy duty intermediate strap, for use in conjunction with the Centaur Single Cable Saddle
- Specially designed for High Voltage, sagged cable systems
- Maintains phase spacing between single cables and offers additional short circuit restraint
- Typical cable size range Ø100mm – Ø162mm (special sizes are available)
- 6000 series aluminium
- Designed, tested and manufactured in accordance with IEC 61914
- Consult Ellis for size and phase spacing availability

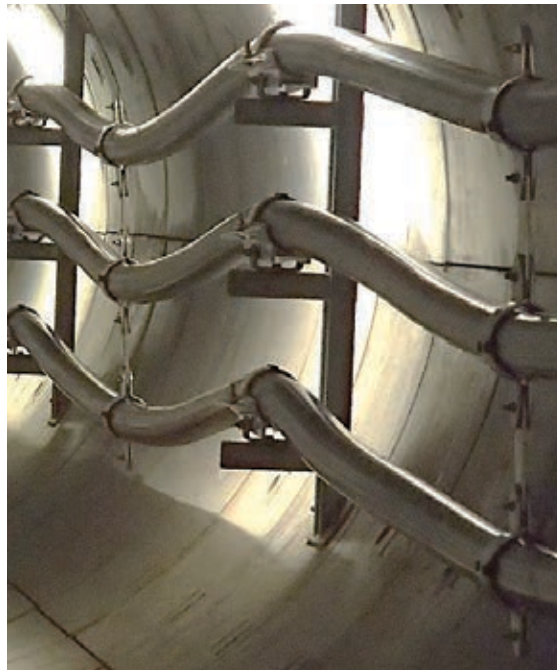

## Testing summary

Centaur cable saddles have been tested in line with the International Standard 'Cable Cleats for Electrical Installations'. As IEC 61914 is part of the low voltage directive it is not possible to follow the standard exactly and thus deviations have been made in areas. Typical results are detailed below, please note that these testing values are maximums and safety factors appropriate to your application should be used:

PROPERTY	CLASSIFICATION CLAUSE IEC 61914	UNITS / CLASSIFICATION	TEST DATA
Cleat type	6.1.3	Composite	-
Temp. For permanent application	6.2	°C	-40 to +60
UV resistance	6.5.1.2	UV resistant	Metallic frame shields all polymer components.
Corrosion resistance	6.5.2.2	Refer to Ellis	-
Impact rating	6.3.5	Very heavy	Pass
Flame propagation test	10.0, 10.1	Application time $\geq 30s$	Pass
Axial load rating	6.4.3, 9.4	Newtons (N)	Refer to Ellis
Lateral load rating	6.4.2, 9.3	Newtons (N)	Refer to Ellis
Resistance to electromechanical force (Short circuit testing)	6.4, 6.4.4, 9.5	Centaur cleats at 8.4m with straps at midpoints	163kA (Report no. KEMA-313-08)  Cable = $\varnothing 140mm$



Single cable formation

# CENTAUR™ TERMINATION CLAMP

Aluminium

## Bespoke Clamp 1

Used in the Woodhead Tunnel, UK.

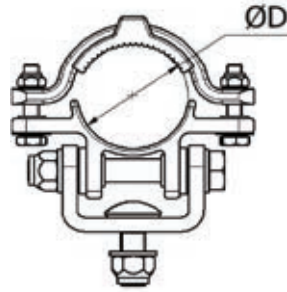

## Bespoke Clamp 2

Used in a Hydroelectric Power Tunnel, USA.

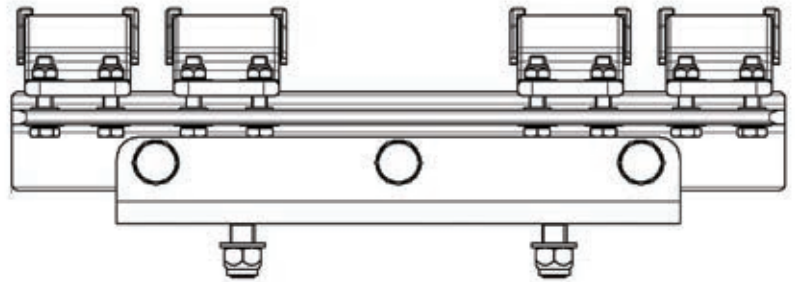

- Heavy duty termination clamp for single cable formation
- Specifically designed for rigid cable restraint at joints, terminations and sharp bends, where high axial thrust restraint is required
- Typical axial force resistance: 10kN – 60kN but the product is designed to project specific requirements
- 6000 series aluminium
- Low Smoke and Fume Zero Halogen (LSF0H), Phosphorus Free polymeric liner, incorporated into the over-strap, for increased cable protection
- Designed, tested and manufactured in accordance with IEC 61914

Typical variable design parameters.

All can be adjusted to suit load requirements and cable pressure constraints.

PIONEER

ENGINEER

CHALLENGER

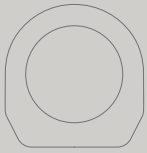

Single cable formation

# 1F ONE HOLE CABLE CLAMP

Polymer

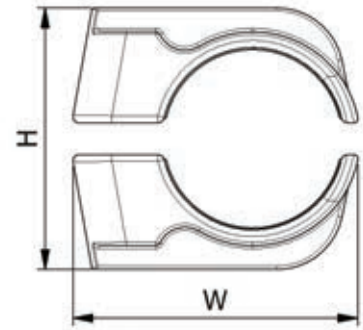
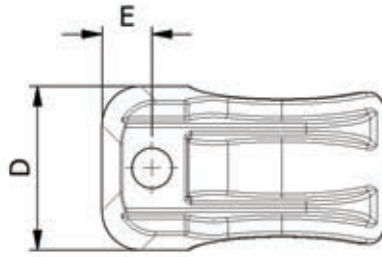

- Light duty cable clamp for single cables
- Cable range of Ø10mm – Ø57mm
- Manufactured as standard in Black Polypropylene (B) or Black Flame Retardant V0 zero Halogen Phosphorus-Free UV Stabilised Nylon (LSF)
- Non-standard London Underground approved material (LUL) also available on request
- Fixing options: one M10 fixing. Fixings are not supplied as standard but are available on request
- Designed, tested and manufactured in accordance with IEC 61914

PART NO.	CABLE RANGE (MM)		DIMENSIONS (MM)				FIXING HOLES	WEIGHT (G)		
	MIN	MAX	W	H	D	E		B	LSF	LUL
1F-10XXX	10	13	37.8	27-30	41.4	10.2	1 x M10	14.6	19.6	23.8
1F-11XXX	13	16	41.2	30-33	41.4	10.4	1 x M10	17.0	23.0	27.7
1F-12XXX	16	19	44.3	33-36	41.4	10.7	1 x M10	19.6	26.4	32.0
1F-13XXX	19	23	48.2	36-40	41.4	10.9	1 x M10	22.4	30.2	36.5
1F-14XXX	23	27	52.2	40-44	41.4	11.3	1 x M10	25.8	34.6	42.0
1F-15XXX	27	32	57.1	44-49	41.4	11.6	1 x M10	29.2	39.0	47.6
1F-16XXX	32	38	63.1	49-55	41.4	12.1	1 x M10	34.2	46.2	55.7
1F-17XXX	38	46	71.3	58-66	41.4	12.9	1 x M10	47.8	64.0	77.9
1F-18XXX	46	51	77.3	67-73	41.4	13.5	1 x M10	54.0	73.2	88.0
1F-19XXX	51	57	83.2	72-78	41.4	13.9	1 x M10	59.0	80.4	96.2

Where ':XXX' add the material required either B, LSF or LUL

## Testing summary

1F Clamps have been tested in line with the International Standard 'Cable Cleats for Electrical Installations' IEC 61914. Typical results are detailed below, please note that these testing values are maximums and safety factors appropriate to your application should be used:

PROPERTY	CLASSIFICATION CLAUSE IEC 61914	UNITS / CLASSIFICATION	TEST DATA	
			LSF	B
Cleat type	6.1.2	Polymeric	-	-
Temp. For permanent application	6.2	°C	-40 - 60	-40 to +40
UV resistance	6.5.1.2	Xenon arc method A	Pass	Pass
Impact rating	6.3.5	Very heavy	Refer to Ellis	Refer to Ellis
Flame propagation test	10.0, 10.1	Application time $\geq 30s$	Pass	Not compliant
Axial load rating	6.4.3, 9.4	Newtons (n)	Refer to Ellis	Refer to Ellis
Lateral load rating	6.4.2, 9.3	Newtons (n)	Refer to Ellis	Refer to Ellis
Resistance to electromechanical force (Short circuit testing)	6.4, 6.4.5, 9.5	Cleats at 300mm intervals (Withstanding more than one short circuit)	10.4kA (Report no. PDL-17.137.2)  (IEC 61914) Phase spacing = 100mm Cable OD= $\varnothing 36mm$	Not short circuit tested

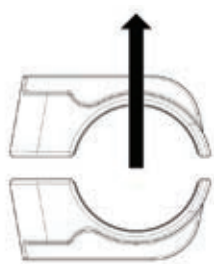

Lateral load:  
vertical direction



Lateral load:  
horizontal direction



Single cable formation

# 2F+ TWO HOLE CABLE CLAMP

Polymer

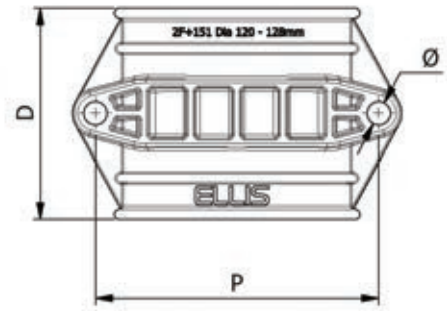
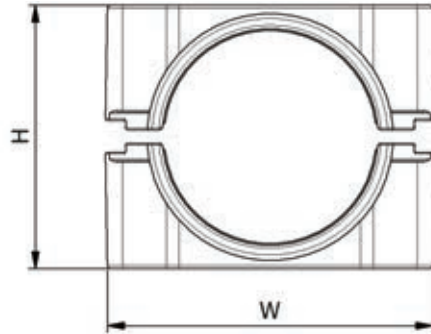

- Standard duty cable clamp for single cable formation
- Cable range of Ø32mm – Ø168mm
- Manufactured as standard in Black Polypropylene (B) or Black Flame Retardant V0 Zero Halogen Phosphorus-Free UV Stabilised Nylon (LSF)
- Non-standard London Underground approved material (LUL) also available on request
- Optional Low Smoke and Fume Zero Halogen (LSFOH), Phosphorus Free polymeric liners available, for increased cable protection
- Fixing options: Two fixings required, sizing shown in table below. Fixings are not supplied as standard but are available on request
- Designed, tested and manufactured in accordance with IEC 61914

PART NO.	CABLE RANGE		LINER THICKNESS (MM)	CABLE RANGE WITH LINER		DIMENSIONS (MM)					WEIGHT (G)		AXIAL LOAD		LATERAL LOAD - HORIZONTAL		LATERAL LOAD - VERTICAL	
	MIN Ø (MM)	MAX Ø (MM)		MIN Ø (MM)	MAX Ø (MM)	W	H	D	P	Ø	LSF	B	LSF	B	LSF	B	LSF	B
2F+07:XXX	38	46	3	32	40	92	68	54	68	2 x M10	91	73	200N	150N	1.75kN	1.5kN	15kN	4kN
2F+08:XXX	46	51	3	40	45	103	76	54	79	2 x M10	110	81	200N	150N	1.75kN	1.5kN	15kN	4kN
2F+09:XXX	51	57	3	45	51	103	82	54	79	2 x M10	119	95	200N	150N	1.75kN	1.5kN	15kN	4kN
2F+10:XXX	57	64	3	51	58	103	89	54	79	2 x M10	123	89	200N	150N	1.75kN	1.5kN	15kN	4kN
2F+11:XXX	64	70	3	58	64	130	95	54	106	2 x M10	157	116	200N	150N	1.75kN	1.5kN	15kN	4kN
2F+1200:XXX	70	76	4	62	68	128	101	75	104	2 x M10	190	160	500N	500N	5kN	1.5kN	15kN	6kN
2F+1201:XXX	76	83	4	68	75	135	107	75	111	2 x M10	207	174	500N	500N	5kN	1.5kN	15kN	6kN
2F+1202:XXX	83	90	4	75	82	143	115	75	119	2 x M10	229	188	500N	500N	5kN	1.5kN	15kN	6kN
2F+131:XXX	90	97	5	80	87	165	122	100	138	2 x M12	423	336	2kN	700N	5kN	3kN	18.5kN	10kN
2F+132:XXX	97	105	5	87	95	171	130	100	144	2 x M12	441	355	2kN	700N	5kN	3kN	18.5kN	10kN
2F+141:XXX	105	112	5	95	102	178	137	100	151	2 x M12	510	382	2kN	700N	5kN	3kN	18.5kN	10kN
2F+142:XXX	112	120	5	102	110	187	146	125	160	2 X M12	622	496	2kN	1.3kN	5kN	4.5kN	18.5kN	8kN
2F+151:XXX	120	128	5	110	118	196	156	125	168	2 X M12	716	537	2kN	1.3kN	5kN	4.5kN	18.5kN	8kN
2F+152:XXX	128	135	5	118	125	203	165	125	176	2 X M12	772	579	2kN	1.3kN	5kN	4.5kN	18.5kN	8kN
2F+161:XXX	135	144	5	125	134	222	177	150	190	2 X M16	1109	831	2.5kN	2kN	30kN	8kN	40kN	15kN
2F+162:XXX	144	152	5	134	142	232	187	150	200	2 X M16	1203	902	2.5kN	2kN	30kN	8kN	40kN	15kN
2F+171:XXX	152	160	5	142	150	242	198	150	210	2 X M16	1302	976	2.5kN	2kN	30kN	8kN	40kN	15kN
2F+172:XXX	160	168	5	150	158	252	209	150	220	2 X M16	1403	1052	2.5kN	2kN	30kN	8kN	40kN	15kN

Where ':XXX' add the material required either B or LSF

For the lined version add 'L' as a suffix to the part no. E.G. '2F+07LSFL'.

## Testing summary

2F+ Clamps have been tested in line with the International Standard 'Cable Cleats for Electrical Installations' IEC 61914. Typical results are detailed below, please note that these testing values are maximums and safety factors appropriate to your application should be used:

PROPERTY	CLASSIFICATION CLAUSE IEC 61914	UNITS / CLASSIFICATION	TEST DATA
Cleat type	6.1, 6.1.3	Polymeric	-
Temp. for permanent application	6.2	°C	LSF: -40 to +60 B:-40 to +40
UV resistance	6.5.1.2	Xenon arc method A	Pass
Impact rating	6.35	Very heavy	Pass
Flame propagation test	10.0, 10.1	Application time $\geq 30s$	LSF: Pass B: Not compliant
Axial load rating	6.4.3, 9.4	Newtons (N)	Refer to previous table data
Lateral load rating	6.4.2, 9.3	Newtons (N)	Refer to previous table data
Resistance to electromechanical force (short circuit testing)	6.4, 6.4.5, 9.5	2F+07LSF cleats at 600mm intervals (withstanding more than one short circuit)	80.2kA (Report No. PDL-17.137.3)  Cable OD= Ø36mm Phase spacing = 100mm
Resistance to electromechanical force (short circuit testing)	6.4, 6.4.5, 9.5	2F+142LSF cleats at 1m intervals (withstanding more than one short circuit)	113kA (Report No. PDL-15.025.1) (Based on IEC 61914)  Cable OD= Ø117mm Phase spacing = 200mm

The test data provided above is for the standard version only, for test data with the liner option please contact Ellis.

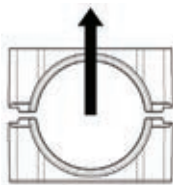

Lateral load:  
vertical direction



Lateral load:  
horizontal direction



# Single cable formation

## SOLUS CLAMP™

Polymer

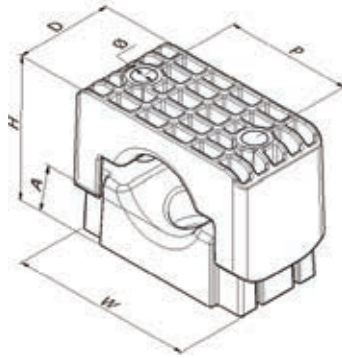

- Standard duty cable clamp for single cable formation
- Stackable design allows easy future cable additions
- Cable range of Ø19mm – Ø90mm
- Available in two materials:
  - Standard material (LSF) is PFAS and halogen free, flame retardant and suitable for outdoor applications
  - For higher temperature applications GFN has the same material properties as LSF but offers a higher operating temperature and the material has a UL94 V-0 flammability rating
- Optional Low Smoke and Fume Zero Halogen (LSF0H), Phosphorus Free polymeric liners available, for increased cable protection
- Fixing options: Single or Twin Bolt fixing options, sizing shown in table below. Fixings are not supplied as standard but are available on request
- Designed, tested and manufactured in accordance with IEC 61914

PART NO.	CABLE RANGE		LINER SIZE (MM)	CABLE RANGE WITH LINER		DIMENSIONS						AXIAL LOAD (KN)		LATERAL LOAD – HORIZONTAL (KN)		LATERAL LOAD – VERTICAL (KN)		WEIGHT (G)
	MIN Ø (MM)	MAX Ø (MM)		MIN Ø (MM)	MAX Ø (MM)	W	H	D	A	P	Ø	SINGLE FIXING	TWIN FIXING	SINGLE FIXING	TWIN FIXING	SINGLE FIXING	TWIN FIXING	
SL25-38GFN	25	38	3	19	32	100	80	60	24	60	M12	0.9	1.2	4	5	6.5	10	285
SL36-52GFN	36	52	3	30	46	116	95	60	24	75	M12	1.2	1.8	4	5.5	6	10	356
SL49-75GFN	49	75	3	43	69	138	124	60	26	95	M12	1.6	1.6	4	10	6.5	9	485
SL66-90GFN	66	90	3	60	84	158	142	70	26	120	M12	1.6	1.6	6.5	10	10	10	655
SL25-38LSF	25	38	3	19	32	100	80	60	24	60	M12	1.1	1.3	6.5	7	10	25	232
SL36-52LSF	36	52	3	30	46	116	95	60	24	75	M12	1.1	1.8	6	8	9	25	287
SL49-75LSF	49	75	3	43	69	138	124	60	26	95	M12	1.1	1.1	6	8	10.5	26	395
SL66-90LSF	66	90	3	60	84	158	142	70	26	120	M12	1.1	1.1	6.5	8	10	25	548

Note: for clamp with liner add 'L' suffix E.G. SL25-38GFNL

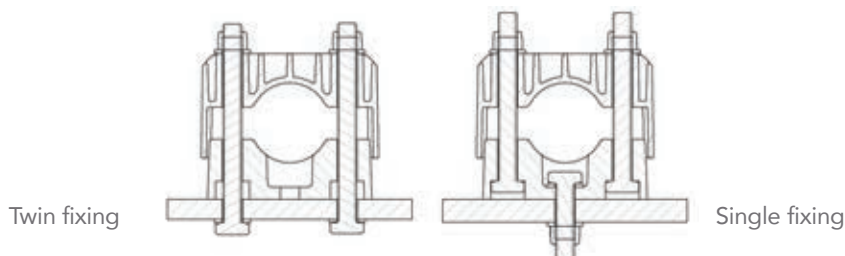

## Testing summary

Solus Clamps have been tested in line with the International Standard 'Cable Cleats for Electrical Installations' IEC 61914. Typical results are detailed below, please note that these testing values are maximums and safety factors appropriate to your application should be used:

PROPERTY	CLASSIFICATION CLAUSE IEC 61914	UNITS / CLASSIFICATION	TEST DATA	
			LSF	GFN
Cleat type	6.1.2	Non-metallic	-	
Temp. for permanent application	6.2	°C	-60 to +60	-60 to +120
Impact rating	6.3.5	Very heavy	Pass	
Flame propagation test	10.0, 10.1	Flame propagation test $\geq 30S$	Pass	
Axial load (KN)	6.4.3, 9.4	Newtons (N)	See table on opposite page	See table on opposite page
Horizontal - 2250N Vertical -2250N	6.4.2, 9.3	Newtons (N)	See table on opposite page	See table on opposite page
Resistance to electromechanical force (short circuit testing)	6.4, 6.4.5, 9.5	Cleats at 300mm intervals (withstanding more than one short circuit)	157kA (Report No. PDL-22.079.02) Cable OD = Ø35mm *Phase spacing = 125mm	164kA (Report No. PDL-22.079.01) Cable OD = Ø35mm *Phase spacing = 125mm
Resistance to electromechanical force (short circuit testing)	6.4, 6.4.5, 9.5	Cleats at 600mm intervals (withstanding more than one short circuit)	136kA (Report No. LCOE 2025 05 35 0317-9) Cable OD = Ø37.5mm #Phase spacing = 125mm	119kA (Report No. LCOE 2025 05 35 0317-8) Cable OD = Ø37.5mm #Phase spacing = 125mm

Note: the with liner version has a lower rating to the standard version as follows:

- 1) Temperature range of -60 to +85°C
  - 2) Axial performance lower than standard version, contact Ellis for details.
- \* Results obtained using 2x M12 316L A4-70 grade stainless steel fixings  
# Results obtained using 2x M10 316L A4-70 grade stainless steel fixings

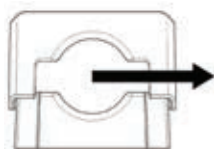

Lateral load:  
vertical direction

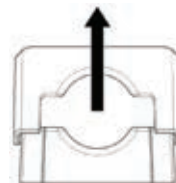

Lateral load:  
horizontal direction



Product can be stacked flat using hex recess on base of product - refer to installation instructions



# Single cable formation NO BOLTS CLEAT™ Polymer

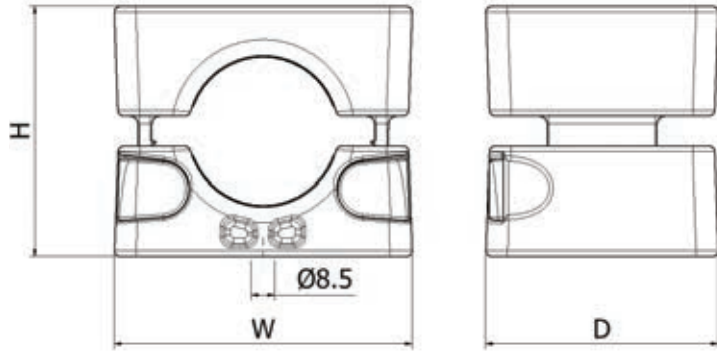

- Light duty cable cleat for single cable formation
- The unique tool-free, boltless design was developed for rapid installation, and the fully non-metallic construction eliminates bi-metallic corrosion
- Stackable design allows easy future cable additions, using the Twist-Foot system
- Designed specifically for controlled environments with rigorous flame-retardancy and fire-safety requirements.
- Cable range of Ø18mm – Ø55mm
- High-strength nylon certified to London Underground 1-085 specification
- Fixings: One M8 fixing. For stacking purposes, available with Twist-Foot base for even faster installation
- Designed, tested and manufactured in accordance with IEC 61914

PART NO. WITH- OUT TWIST FOOT	PART NO. WITH TWIST FOOT	NETWORK RAIL PADS#	CABLE RANGE	DIMENSIONS (MM)			FIXING HOLES	WEIGHT (G)
				W	H	D		
NBC18-22	NBC18-22TF	0111/120321	18 - 22	109	91	90	1 x M8	830
NBC20-26	NBC20-26TF	0111/120322	20 - 26	109	91	90	1 x M8	815
NBC24-30	NBC24-30TF	0111/120323	24 - 30	109	91	90	1 x M8	808
NBC28-34	NBC28-34TF	0111/120324	28 - 34	109	91	90	1 x M8	801
NBC32-39	NBC32-39TF	0111/120325	32 - 39	109	91	90	1 x M8	792
NBC37-47	NBC37-47TF	0111/120133	37 - 47	109	91	90	1 x M8	758
NBC45-55*	NBC45-55TF*	0111/120134	45 - 55	109	91	85	1 x M8	675

Note: the cleat range is covered by a set of inserts that sit inside the main body, therefore all outside dimensions are the same. \*NBC45-55 does not use inserts.

The product is registered with Network Rail PADS System as an uncontrolled item, as such it is not searchable on pads. PADS numbers are for the twist foot version of the product.



This product can be stacked a maximum of three high by using the twist foot variant. This version locks into the recess provided in the top of the clamps. Due to tolerances of standard unistrut style profile, Ellis recommend using fixings to fasten the clamp to the channel.

## Testing summary

No Bolts Cleat has been tested in line with the International Standard 'Cable Cleats for Electrical Installations' IEC 61914. Typical results are detailed below, please note that these testing values are maximums and safety factors appropriate to your application should be used:

PROPERTY	CLASSIFICATION CLAUSE IEC 61914	UNITS / CLASSIFICATION	TEST DATA
Cleat type	6.1.2	Polymeric	-
Temp. for permanent application	6.2	°C	-40 to +60
Impact rating	6.3.5	Very heavy	Pass
Flame propagation test	10.0, 10.1	Application time $\geq$ 30s	Pass
Axial load rating	6.4.3, 9.4	Newtons (N)	Refer to Ellis
Lateral load rating	6.4.2, 9.3	Newtons (N)	Refer to Ellis
Resistance to electromechanical force (short circuit testing)	6.4, 6.4.5, 9.5	Cleats at 300mm intervals (withstanding more than one short circuit)	101kA (Report No. PDL-16.016)  Phase spacing = 110mm Cable OD= Ø36mm
Resistance to electromechanical force (short circuit testing)	6.4, 6.4.5, 9.5	Cleats at 300mm intervals (withstanding more than one short circuit)	71kA (Report No. PDL-16.016)  Tested in stacked formation  Phase spacing = 75mm Cable OD= Ø36mm

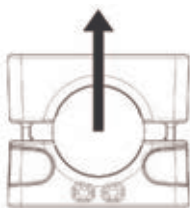

Lateral load:  
vertical direction

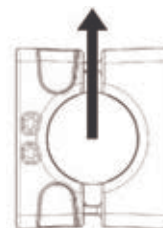

Lateral load:  
horizontal direction



# Single cable formation CABLE GUIDE CLAMP

Polymer

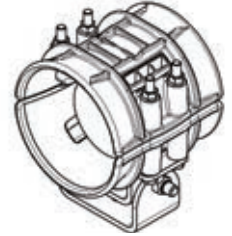
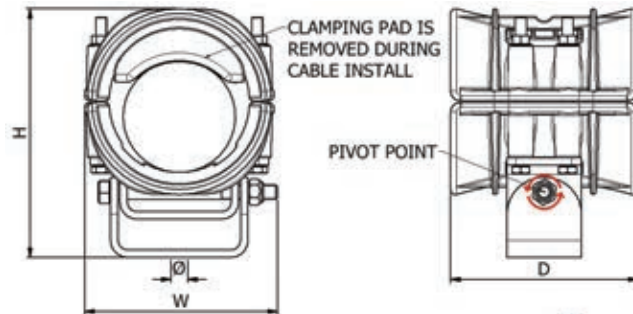

- Standard duty cable clamp for single cable formation
- Unique combination of cable guide and cable clamp, designed to support HV cable pulling before offering short circuit protection once in situ
- Cable range of Ø100mm – Ø170mm (non-standard sizes available on request)
- High strength Glass Filled Nylon clamp (UL94 V0)
- Low Smoke and Fume Zero Halogen (LSF0H), Phosphorus Free polymeric insert
- Galvanised steel gimballed mount
- Fixing options: one M16 fixing
- Designed, tested and manufactured in accordance with IEC 61914

PART NO.	CABLE RANGE		DIMENSIONS (MM)				WEIGHT (KG)
	MIN Ø	MAX Ø	W	H	D	Ø FIXING HOLES	
CGC100-112-G	100	112	185	260	200	1 x M16	5.2
CGC110-122-G	110	122	185	255	200	1 x M16	5.2
CGC120-135-G	120	135	203	281	200	1 x M16	5.5
CGC130-145-G	130	145	203	283	200	1 x M16	5.5
CGC140-160-G	140	160	262	324	250	1 x M16	6.25
CGC150-170-G	150	170	262	324	250	1 x M16	6.25

## Testing summary

Cable Guide Clamp has been tested in line with the International Standard 'Cable Cleats for Electrical Installations' IEC 61914. As IEC 61914 is part of the low voltage directive it is not possible to follow the standard exactly and thus deviations have been made in areas. Typical results are detailed below, please note that these testing values are maximums and safety factors appropriate to your application should be used:

PROPERTY	CLASSIFICATION CLAUSE IEC 61914	UNITS / CLASSIFICATION	TEST DATA
Cleat type	6.1.3	Composite	-
Temp. for permanent application	6.2	°C	-40 to +60
Corrosion resistance	6.5.2.2	High	192h salt spray test - ISO 9227
Impact rating	6.3.5	Very heavy	Pass
Flame propagation test	10.0, 10.1	Application time ≥30s	Pass
Axial load rating	6.4.3, 9.4	Newtons (N)	Refer to Ellis
Lateral load rating	6.4.2, 9.3	Newtons (N)	Refer to Ellis
Resistance to electromechanical force (short circuit testing)	6.4, 6.4.5, 9.5	Cleats at 1m intervals (withstanding more than one short circuit)	114kA (Report No. PDL-15.025.1)  Cable OD= Ø117mm  Phase spacing = 200mm

# TREFOIL CABLE FORMATION

Ellis' trefoil cable cleats are engineered to securely retain, and support three single-core cables installed in trefoil formation, providing effective control of electromagnetic forces during normal operation and short-circuit fault conditions. Designed for use across LV, MV and HV installations, the range is proven in demanding industrial environments including energy, infrastructure, mining and process industries.

Developed with both performance and installation efficiency in mind, Ellis' trefoil cable cleats incorporate installer-focused design features that allow flexibility during installation, particularly in areas with restricted access or limited working space. Options such as top-opening designs and adaptable fixing arrangements enable faster, safer installation while maintaining consistent clamping force and long-term cable support.

The trefoil range accommodates a broad spectrum of cable diameters and is available in multiple material options, including metallic and advanced polymer solutions, to suit environmental, mechanical and regulatory requirements. This ensures compliance, durability and dependable performance across a wide range of applications and support structures.

## TREFOIL CABLE FORMATION

<b>Stainless steel</b>	
Vulcan+™	52
Vulcan+™ Twist-Foot	54
Emperor™ Trefoil	56
Emperor™ Trefoil Twist-Foot	58
Colossus™	60
Flexi-Strap™	62
Protect™	64
<b>Galvanised Steel</b>	
Atlas™	66
<b>Aluminium</b>	
Alpha™	68
Centaur® Trefoil	70
Centaur® Spaced Intermediate Strap	72
<b>Polymer</b>	
Trident®	74
Trident® With Spacer	76

The data sheets are subject to change without notice. The information provided has been generated in laboratory conditions, as such results in use may vary.

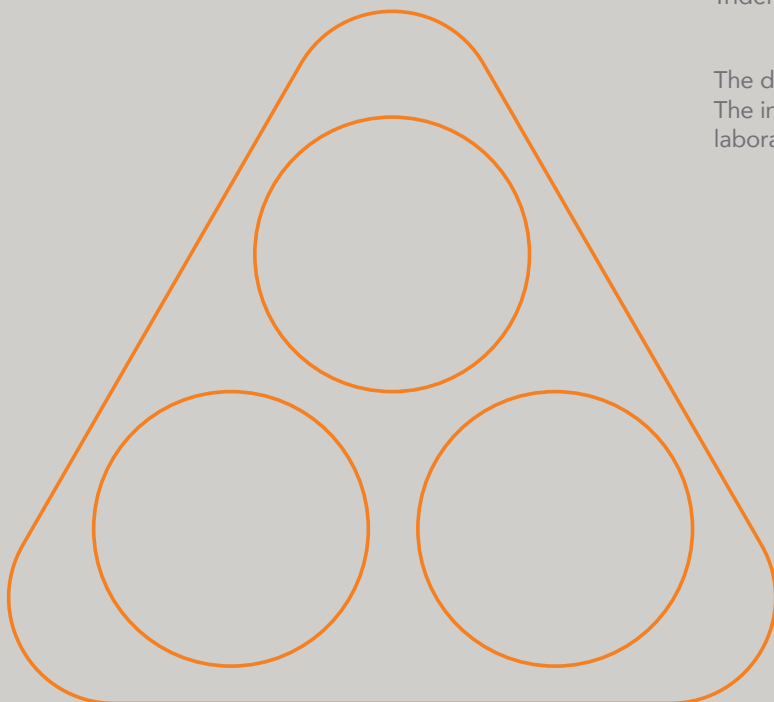



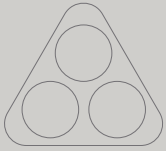

Trefoil formation  
**VULCAN+™**  
 Stainless steel

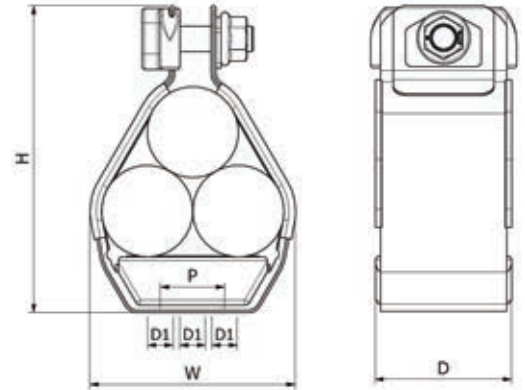

- Standard duty cable cleat for trefoil cable formation
- Cable range of Ø10mm – Ø101mm
- 316L stainless steel frame with A4-70 stainless steel captive closure fixings
- Low Smoke and Fume Zero Halogen (LSFOH), Phosphorus Free polymeric liners for increased cable protection
- Fixing options: one or two M10 fixings (cleat size dependent as listed in table)
- ABS and DNV type approved and UL listed
- Designed, tested and manufactured in accordance with IEC 61914

PART NO.	CABLE RANGE		DIMENSIONS (mm)					WEIGHT (g)
	MIN Ø (mm)	MAX Ø (mm)	W MAX	D ±1	H ±5	P ±0.5	FIXING HOLES (D1)	
VRT+00C	10	15	57	56	94	N/A	1 x M10	276
VRT+00A	15	18	60	54	93	N/A	1 x M10	287
VRT+00	19	24	60	54	92	N/A	1 x M10	251
VRT+01	23	28	66	54	100	N/A	1 x M10	258
VRT+02	27	32	74	54	108	N/A	1 x M10	269
VRT+03	30	35	80	54	113	N/A	1 x M10	279
VRT+04	33	38	86	54	119	N/A	1 x M10	284
VRT+05	36	42	94	54	125	N/A	1 x M10	319
VRT+06	40	46	102	54	134	N/A	1 x M10	331
VRT+07	44	50	110	54	140	N/A	1 x M10	391
VRT+08	48	55	120	54	151	N/A	1 x M10	405
VRT+09	51	58	126	54	156	N/A	1 x M10	411
VRT+10	55	62	134	54	162	50	3 x M10	442
VRT+11	59	66	142	54	168	50	3 x M10	453
VRT+12	63	70	150	54	178	50	3 x M10	460
VRT+13	67	74	158	54	185	75	3 x M10	524
VRT+14	71	78	166	54	196	75	3 x M10	536
VRT+15	74	82	174	54	202	75	3 x M10	542
VRT+16	77	85	180	54	206	75	3 x M10	544
VRT+17	81	89	188	54	212	75	3 x M10	618
VRT+18	85	93	196	54	217	75	3 x M10	628
VRT+19	89	97	204	54	222	75	3 x M10	637
VRT+20	93	101	212	54	230	75	3 x M10	646

## Testing summary

Vulcan+ Cleats have been tested in line with the International Standard 'Cable Cleats for Electrical Installations' IEC 61914. Typical results are detailed below, please note that these testing values are maximums and safety factors appropriate to your application should be used:

PROPERTY	CLASSIFICATION CLAUSE IEC 61914	UNITS / CLASSIFICATION	TEST DATA
Cleat type	6.1.3	Composite	-
Temp. For permanent application	6.2	°C	-40 to +60
UV resistance	6.5.1.2	Xenon arc method A	Pass
Corrosion resistance	6.5.2.2	High	316L stainless steel has ≥16% chromium
Impact rating	6.3.4	Very heavy	Pass
Flame propagation test	10.0, 10.1	Application time ≥30s	Pass
Axial load rating	6.4.3, 9.4	Newtons (N)	280N - Trefoil (VRT+00C/A=80N)
Lateral load rating	6.4.2, 9.3	Newtons (N)	Horizontal - 200N (VRT+00C=180N) Vertical - 650N
Resistance to electromechanical force (short circuit testing)	6.4, 6.4.5, 9.5	Cleats at 300mm intervals (withstanding more than one short circuit)	135kA (Report No. LCOE 2025 09 35 0695-7)  Cable OD= Ø35.5mm
Resistance to electromechanical force (short circuit testing)	6.4, 6.4.5, 9.5	Cleats at 600mm intervals (withstanding more than one short circuit)	116kA (Report No. LCOE 2025 09 35 0695-8)  Cable OD= Ø35.7mm



Lateral load:  
vertical direction

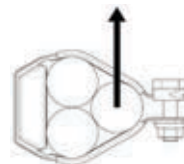

Lateral load:  
horizontal direction

Listed sizes:  
VRT+00 to  
VRT+20



Conduit & cable hardware 4CG8 with  
AH-2 & wet locations. Listed sizes:  
VRT+00 to VRT+18.

LONDON UNDERGROUND  
Vulcan+ Cable Cleats are compliant  
with the requirements of LUL-1085.  
Product register number 361.

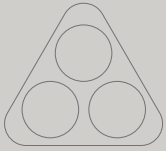

Trefoil formation

# VULCAN+™ TREFOIL TWIST FOOT

Stainless steel

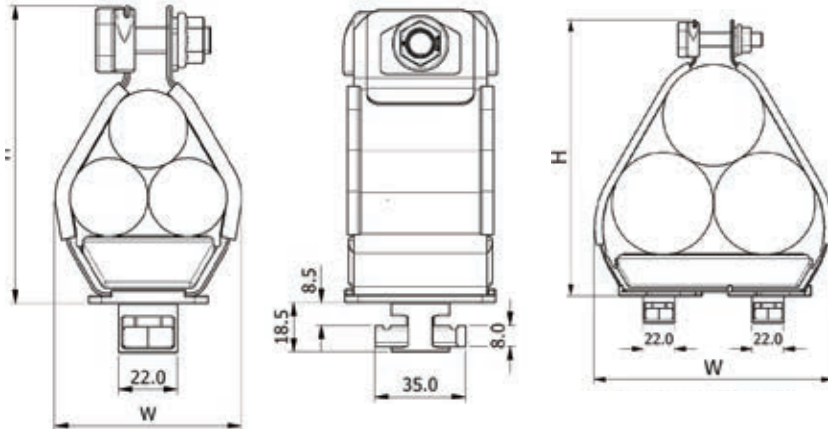

- Vulcan+™ cable cleat supplied with an integrated Twist-Foot base fixing kit
- Designed for rapid installation into 41×41mm and 41×21mm unistrut channel or ladder with inverted rungs
- All fixings supplied pre-assembled – no additional site fixings required
- Standard duty cable cleat for single cable formation
- Cable range of Ø15mm – Ø101mm
- Single-foot versions for cables up to Ø70mm
- Double-foot versions for cables Ø67mm – Ø101mm
- Fixing kits available in A4 stainless steel, galvanised steel or zinc-plated steel
- Designed, tested and manufactured in accordance with IEC 61914

PART NO.	CABLE RANGE		DIMENSIONS (MM)			WEIGHT (g)
	MIN Ø (MM)	MAX Ø (MM)	W	H	D	
VRT+00ATFM10-X	15	18	64	96	54	337
VRT+00TFM10-X	19	24	60	96	54	301
VRT+01TFM10-X	23	28	63	102	54	308
VRT+02TFM10-X	27	32	72	109	54	319
VRT+03TFM10-X	30	35	79	115	54	329
VRT+04TFM10-X	33	38	85	121	54	334
VRT+05TFM10-X	36	42	96	128	54	369
VRT+06TFM10-X	40	46	105	137	54	381
VRT+07TFM10-X	44	50	112	143	54	441
VRT+08TFM10-X	48	55	121	152	54	455
VRT+09TFM10-X	51	58	126	158	54	461
VRT+10TFM10-X	55	62	134	166	54	492
VRT+11TFM10-X	59	66	143	174	54	503
VRT+12TFM10-X	63	70	152	181	54	510
VRT+13TTFM10-X	67	74	161	188	70	574
VRT+14TTFM10-X	71	78	169	195	70	586
VRT+15TTFM10-X	74	82	176	199	70	592
VRT+16TTFM10-X	77	85	183	208	70	594
VRT+17TTFM10-X	81	89	190	219	70	668
VRT+18TTFM10-X	85	93	200	228	70	678
VRT+19TTFM10-X	89	97	200	238	70	687
VRT+20TTFM10-X	93	101	215	243	70	696

## Testing summary

Vulcan+ Cleats have been tested in line with the International Standard 'Cable Cleats for Electrical Installations' IEC 61914. Typical results are detailed below, please note that these testing values are maximums and safety factors appropriate to your application should be used:

PROPERTY	CLASSIFICATION CLAUSE IEC 61914	UNITS / CLASSIFICATION	TEST DATA
Cleat type	6.1.3	Composite	-
Temp. For permanent application	6.2	°C	-40 to +60
Uv resistance	6.5.1.2	Xenon arc method A	Pass
Corrosion resistance	6.5.2.2	High	316L stainless steel has ≥16% chromium
Impact rating	6.3.4	Very heavy	Pass
Flame propagation test	10.0, 10.1	Application time ≥30s	Pass
Axial load rating	6.4.3, 9.4	Newtons (N)	280N - Trefoil (VRT+00C/A=80N)
Lateral load rating	6.4.2, 9.3	Newtons (N)	Horizontal - 200N Vertical - 650N
Resistance to electromechanical force (short circuit testing)	6.4, 6.4.5, 9.5	Cleats at 300mm intervals (withstanding more than one short circuit)	135kA (Report No. LCOE 2025 09 35 0695-7)  Cable OD= Ø35.5mm
Resistance to electromechanical force (short circuit testing)	6.4, 6.4.5, 9.5	Cleats at 600mm intervals (withstanding more than one short circuit)	116kA (Report No. LCOE 2025 09 35 0695-8)  Cable OD= Ø35.7mm



Lateral load:  
vertical direction

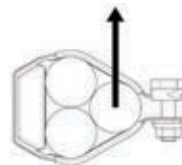

Lateral load:  
horizontal direction

X denotes fixing material, options are as follows:  
 4 = A4 stainless steel  
 G = Galvanised steel  
 Z = Zinc plated steel  
 e.g A VRT+04 with stainless steel twist foot fixings  
 becomes: VRT+04TFM10-4



Click to see how  
easy the Twist-Foot  
is to install.

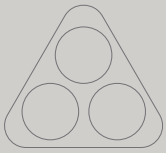

# Trefoil formation EMPEROR™ TREFOIL

Stainless steel

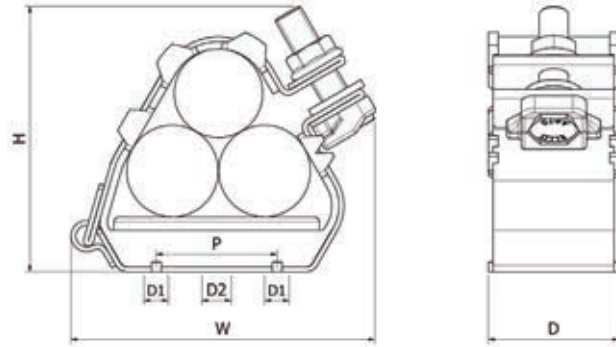

- Heavy duty cable cleat for trefoil cable formation
- Cable range of Ø19mm – Ø128mm
- 316L stainless steel frame with A4-70 stainless steel captive closure fixings
- Low Smoke and Fume Zero Halogen (LSFOH), Phosphorus Free polymeric liners for increased cable protection
- Fixing options: two M10 fixings or one M12 fixing
- ABS and DNV type approved and UL listed
- Designed, tested and manufactured in accordance with IEC 61914

PART NO.	CABLE RANGE		DIMENSIONS (MM)					WEIGHT (G)
	MIN Ø (MM)	MAX Ø (MM)	W	H	D	P	FIXING HOLES (D1 & D2)	
ER19-23	19	23	96	83	54	25	2 x M10 + 1 x M12	425
ER23-28	23	28	96	83	54	25	2 x M10 + 1 x M12	425
ER27-32	27	32	97	88	54	25	2 x M10 + 1 x M12	440
ER30-35	30	35	99	91	54	25	2 x M10 + 1 x M12	445
ER33-38	33	38	103	95	54	25	2 x M10 + 1 x M12	460
ER36-42	36	42	124	100	54	50	2 x M10 + 1 x M12	600
ER40-46	40	46	125	106	54	50	2 x M10 + 1 x M12	605
ER44-50	44	50	130	117	54	50	2 x M10 + 1 x M12	630
ER48-55	48	55	132	121	54	50	2 x M10 + 1 x M12	640
ER51-58	51	58	136	128	54	50	2 x M10 + 1 x M12	650
ER55-62	55	62	160	135	54	75	2 x M10 + 1 x M12	810
ER59-66	59	66	163	143	54	75	2 x M10 + 1 x M12	825
ER63-70	63	70	166	151	54	75	2 x M10 + 1 x M12	850
ER67-74	67	74	169	158	54	75	2 x M10 + 1 x M12	850
ER71-78	71	78	172	165	54	75	2 x M10 + 1 x M12	890
ER74-82	74	82	177	171	54	75	2 x M10 + 1 x M12	890
ER77-85	77	85	183	177	54	75	2 x M10 + 1 x M12	905
ER82-88	82	88	191	187	54	75	2 x M10 + 1 x M12	820
ER88-96	88	96	207	203	54	75	2 x M10 + 1 x M12	890
ER96-103	96	103	221	218	54	75	2 x M10 + 1 x M12	940
ER103-111	103	111	237	235	54	75	2 x M10 + 1 x M12	950
ER111-119	111	119	253	250	54	75	2 x M10 + 1 x M12	1010
ER119-128	119	128	265	275	54	75	2 x M10 + 1 x M12	1220

## Testing summary

Emperor Cleats have been tested in line with the International Standard 'Cable Cleats for Electrical Installations' IEC 61914. Typical results are detailed below, please note that these testing values are maximums and safety factors appropriate to your application should be used:

PROPERTY	CLASSIFICATION CLAUSE IEC 61914	UNITS / CLASSIFICATION	TEST DATA
Cleat type	6.1.3	Composite	
Temp. for permanent application	6.2	°C	-40 to +60
UV resistance	6.5.1.2	Xenon arc method A	Pass
Corrosion resistance	6.5.2.2	High	316L stainless steel has≥16% chromium
Impact rating	6.3.5	Very heavy	Pass
Flame propagation test	10.0, 10.1	Application time ≥30s	Pass
Axial load rating	6.4.3, 9.4	Newtons (N)	400N
Lateral load rating	6.4.2, 9.3	Newtons (N)	Horizontal - 650N Vertical -1000N
Resistance to electromechanical force (short circuit testing)	6.4, 6.4.4, 9.5	Cleats at 300mm intervals (withstanding one short circuit)	195kA (Report No. PDL-09.098.2)  Cable OD= Ø38mm (IEC 61914:2009)
Resistance to electromechanical force (short circuit testing)	6.4, 6.4.5, 9.5	Cleats at 600mm intervals (withstanding more than one short circuit)	149kA (Report No. PDL-17.137.4)  Cable OD= Ø36mm



Lateral load:  
vertical direction



Lateral load:  
horizontal direction



Conduit & cable hardware 4CG8 with  
AH-2 & wet locations. Listed sizes:  
ER19-23 to ER82-88.

LONDON UNDERGROUND  
Emperor Cable Cleats are compliant  
with the requirements of LUL-1085.  
Product register number 362.

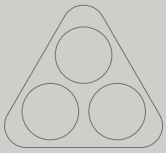

Trefoil formation

# EMPEROR™ TREFOIL TWIST FOOT

Stainless steel

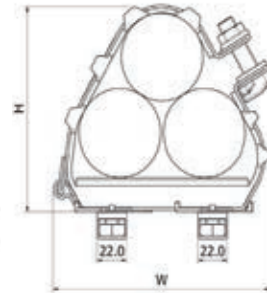
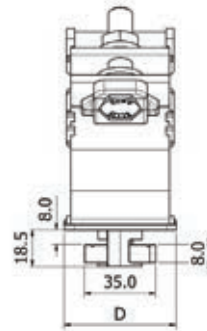
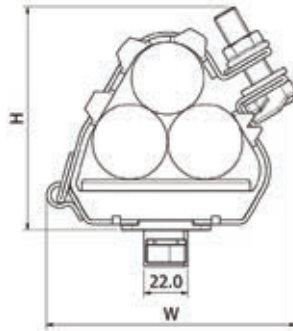

Single fix twist foot: ER19-23 to ER51-58

Twin fix twist foot: ER55-62 to ER119-128

- Emperor™ Trefoil cable cleat supplied with an integrated Twist-Foot base fixing kit
- Designed for rapid installation into 41×41mm and 41×21mm unistrut channel or ladder with inverted rungs
- All fixings supplied pre-assembled – no additional site fixings required
- Heavy duty cable cleat for trefoil cable formation
- Cable range of Ø19mm – Ø128mm
- 316L stainless steel frame with A4-70 stainless steel captive closure fixings
- Low Smoke and Fume Zero Halogen (LSFOH), Phosphorus Free polymeric liners for increased cable protection
- Single-foot versions for cables up to Ø58mm
- Double-foot versions for cables Ø55mm – Ø128mm
- Fixing kits available in A4 stainless steel, galvanised steel or zinc-plated steel
- Designed, tested and manufactured in accordance with IEC 61914

PART NO.	CABLE RANGE		DIMENSIONS (MM)			WEIGHT (g)
	MIN Ø (MM)	MAX Ø (MM)	W	H	D	
ER19-23TFM12-X	19	23	96	86	54	475
ER23-28TFM12-X	23	28	96	86	54	475
ER27-32TFM12-X	27	32	97	91	54	490
ER30-35TFM12-X	30	35	99	94	54	495
ER33-38TFM12-X	33	38	103	98	54	510
ER36-42TFM12-X	36	42	124	103	54	660
ER40-46TFM12-X	40	46	125	109	54	655
ER44-50TFM12-X	44	50	130	120	54	680
ER48-55TFM12-X	48	55	132	124	54	690
ER51-58TFM12-X	51	58	136	131	54	700
ER55-62TTFM10-X	55	62	160	138	70	810
ER59-66TTFM10-X	59	66	163	146	70	825
ER63-70TTFM10-X	63	70	166	154	70	950
ER67-74TTFM10-X	67	74	169	161	70	950
ER71-78TTFM10-X	71	78	172	168	70	990
ER74-82TTFM10-X	74	82	177	174	70	990
ER77-85TTFM10-X	77	85	183	180	70	1005
ER82-88TTFM10-X	82	88	191	190	70	920
ER88-96TTFM10-X	88	96	207	206	70	990
ER96-103TTFM10-X	96	103	221	221	70	1040
ER103-111TTFM10-X	103	111	237	238	70	1050
ER111-119TTFM10-X	111	119	253	253	70	1110
ER119-128TTFM10-X	119	128	265	278	70	1320

## Testing summary

Emperor Cleats have been tested in line with the International Standard 'Cable Cleats for Electrical Installations' IEC 61914. Typical results are detailed below, please note that these testing values are maximums and safety factors appropriate to your application should be used:

PROPERTY	CLASSIFICATION CLAUSE IEC 61914	UNITS / CLASSIFICATION	TEST DATA
Cleat type	6.1.3	Composite	
Temp. for permanent application	6.2	°C	-40 to +60
UV resistance	6.5.1.2	Xenon arc method A	Pass
Corrosion resistance	6.5.2.2	High	316L stainless steel has ≥16% chromium
Impact rating	6.3.5	Very heavy	Pass
Flame propagation test	10.0, 10.1	Application time ≥30s	Pass
Axial load rating	6.4.3, 9.4	Newtons (N)	400N
Lateral load rating	6.4.2, 9.3	Newtons (N)	Horizontal - 650N Vertical -1000N
Resistance to electromechanical force (short circuit testing)	6.4, 6.4.4, 9.5	Cleats at 300mm intervals (withstanding one short circuit)	195kA (Report No. PDL-09.098.2)  Cable OD= Ø38mm (IEC 61914:2009)
Resistance to electromechanical force (short circuit testing)	6.4, 6.4.5, 9.5	Cleats at 600mm intervals (withstanding more than one short circuit)	149kA (Report No. PDL-17.137.4)  Cable OD= Ø36mm



Lateral load:  
vertical direction



Lateral load:  
horizontal direction

X Denotes fixing material, options are as follows:

4 = A4 stainless steel  
G = Galvanised steel  
Z = Zinc plated steel

E.G A ER33-38 with stainless steel twist foot fixings  
becomes: ER33-38TFM10-4



Click to see how  
easy the Twist-Foot  
is to install.

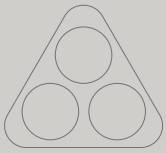

Trefoil formation  
**COLOSSUS™**  
 Stainless steel

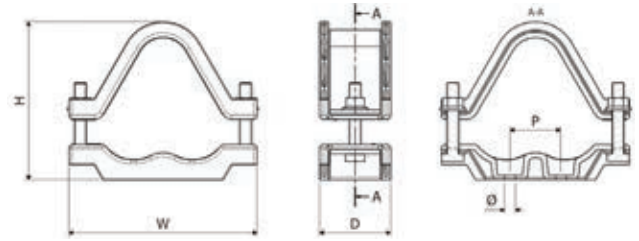

- Heavy duty cable cleat for trefoil cable formation
- Cable range of Ø60mm – Ø170mm
- 316L stainless steel frame with A4-70 stainless steel closure fixings
- Low Smoke and Fume Zero Halogen (LSFOH), Phosphorus Free polymeric base and top moulding to protect cable sheath
- Optional saddled base available for snaked cable applications, with larger cleat spacing requirements
- Fixing options: Method varies depending on cleat size, details shown in table below.
- Designed, tested and manufactured in accordance with IEC 61914

PART NO.	CABLE RANGE		DIMENSIONS (mm)					WEIGHT (g)
	MIN Ø	MAX Ø	W	H	D	P	Ø FIXING HOLES	
COL60-72	60	72	204	176	70	50	2 x M10	1063
COL69-83	69	83	225	202	100	75	2 x M12	1590
COL79-95	79	95	247	225	100	75	2 x M12	1700
COL91-109	91	109	273	253	100	120	2 x M12	1900
COL105-126	105	126	306	286	150	120	2 x M12	3030
COL122-146	122	146	345	324	150	150	2 x M12	3270
COL142-170	142	170	390	371	150	150	2 x M12	3680
<b>SADDLED COLOSSUS CLEAT</b>								
COL60-72SC	60	72	207	176	300	50	2 X M12	1435
COL69-83SC	69	83	225	202	300	75	2 X M12	2532
COL79-95SC	79	95	247	225	300	75	2 X M12	2726
COL91-109SC	91	109	273	253	300	120	2 X M12	2995
COL105-126SC	105	126	306	286	300	120	2 X M12	4108
COL122-146SC	122	146	345	324	300	150	2 X M12	4562

## Testing summary

Colossus Cleats have been tested in line with the International Standard 'Cable Cleats for Electrical Installations' IEC 61914. Typical results are detailed below, please note that these testing values are maximums and safety factors appropriate to your application should be used:

PROPERTY	CLASSIFICATION CLAUSE IEC 61914	UNITS / CLASSIFICATION	TEST DATA
Cleat type	6.1.3	Composite	-
Temp. for permanent application	6.2	°C	-40 to +60
Corrosion resistance	6.5.2.2	High	316L stainless steel has ≥16% chromium
Impact rating	6.3.5	Very heavy	Pass
Flame propagation test	10.0, 10.1	Application time ≥30s	Pass
Axial load rating	6.4.3, 9.4	Newtons (N)	100N
Lateral load rating	6.4.2, 9.3	Newtons (N)	Horizontal - 500N Vertical - 1000N
Resistance to electromechanical force (short circuit testing)	6.4, 6.4.4, 9.5	Cleats at 300mm intervals (withstanding one short circuit)	170kA (Report No. PDL-18.122) Cable OD= Ø36mm
Resistance to electromechanical force (short circuit testing)	6.4, 6.4.5, 9.5	Cleats at 600mm intervals (withstanding more than one short circuit)	150kA (Report No. PDL-16.164.2) Cable OD= Ø36mm
Resistance to electromechanical force (short circuit testing)	6.4, 6.4.5, 9.5	Cleats at 7.8m intervals with straps at midpoints (withstanding more than one short circuit)	104kA (Report No. ZKU-12-179) Cable OD= Ø70mm  (With protect straps every 1.3m)

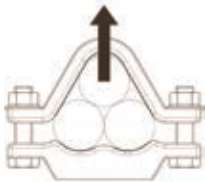

Lateral load:  
vertical direction

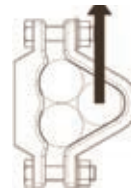

Lateral load:  
horizontal direction

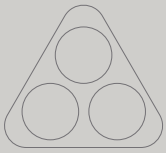

Trefoil formation  
**FLEXI-STRAP™**  
 Stainless steel

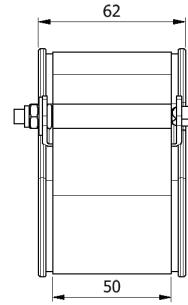
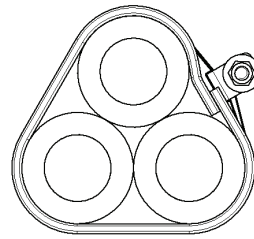

- Intermediate cable strap for trefoil cables or bundled cables
- Utilised between fixed cleats to offer a more cost-effective installation, whilst maintaining short circuit protection
- Available in two short circuit performance levels: The Standard Duty (SDL) version and the Heavy Duty (HDL) version
- Cable range of Ø24mm – Ø145mm
- 316L stainless steel strap with A4-70 stainless steel closure fixing
- Low Smoke and Fume Zero Halogen (LSF0H), Phosphorus Free polymeric liner for increased cable protection
- Designed, tested and manufactured in accordance with IEC 61914

### Standard Duty

PART NO.	CABLE RANGE		WEIGHT (G)
	MIN Ø (MM)	MAX Ø (MM)	
FS24-34SDL	24	34	190
FS30-41SDL	30	41	195
FS37-47SDL	37	47	224
FS43-54SDL	43	54	260
FS50-60SDL	50	60	273
FS56-67SDL	56	67	303
FS63-73SDL	63	73	324
FS69-80SDL	69	80	347
FS72-85SDL	72	85	364
FS82-95SDL	82	95	398
FS92-105SDL	92	105	431
FS102-115SDL	102	115	452
FS112-125SDL	112	125	499
FS122-135SDL	122	135	532
FS132-145SDL	132	145	550

### Heavy Duty

PART NO.	CABLE RANGE		WEIGHT (G)
	MIN Ø (MM)	MAX Ø (MM)	
FS24-34HDL	24	34	219
FS30-41HDL	30	41	243
FS37-47HDL	37	47	268
FS43-54HDL	43	54	313
FS50-60HDL	50	60	344
FS56-67HDL	56	67	353
FS63-73HDL	63	73	391
FS69-80HDL	69	80	433
FS72-85HDL	72	85	438
FS82-95HDL	82	95	483
FS92-105HDL	92	105	523
FS102-115HDL	102	115	568
FS112-125HDL	112	125	633
FS122-135HDL	122	135	675
FS132-145HDL	132	145	719

## Testing summary

Flexi-Straps have been tested in line with the International Standard 'Cable Cleats for Electrical Installations' IEC61914. Typical results are detailed below, please note that these testing values are maximums and safety factors appropriate to your application should be used:

PROPERTY	CLASSIFICATION CLAUSE IEC 61914	UNITS / CLASSIFICATION	TEST DATA (STANDARD DUTY)	TEST DATA (HEAVY DUTY)
Cleat type	6.1.3	Composite	N/A	N/A
Temp. for permanent application	6.2	°C	-40 - 60	-40 to +60
corrosion resistance	6.5.2.2	High	316L stainless steel has≥16% chromium	316L stainless steel has≥16% chromium
Impact rating	6.3.5	Very heavy	Pass	Pass
Flame propagation test	10.0, 10.1	Application time ≥30s	Pass	Pass
Resistance to electromechanical force (short circuit testing)	6.4, 6.4.4, 9.5	Cleats at 300mm intervals	164kA (Report No. PDL-18.071.8)  Cable OD= Ø36mm CAT1	206kA (Report No. PDL-23.183)  Cable OD= Ø41.1mm CAT1
Resistance to electromechanical force (short circuit testing)	6.4, 6.4.5, 9.5	Cleats at 600mm intervals	121.8kA (Report No. 2024 10 3S 0745-7)  Cable OD= Ø37.5mm CAT2	157kA (Report No. PDL 14.076.9)  Cable OD= Ø39mm CAT2

### Ultimate flexibility

Flexi-Strap is also suitable for quad and multiple cable formations. Please contact Ellis directly for relevant short-circuit information in relation to this.

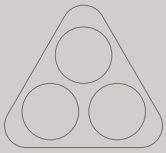

Trefoil formation  
**PROTECT™**  
 Stainless steel

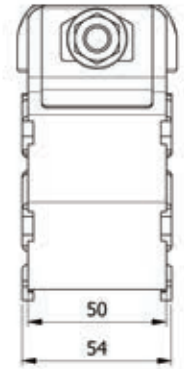
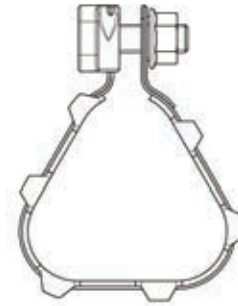

- Standard duty intermediate strap for trefoil cables
- Utilised between fixed cleats to offer a more cost-effective installation, whilst maintaining short circuit protection
- Strap size and dimensional data available on request
- 316L stainless steel frame with A4-70 stainless steel closure fixing
- Low Smoke and Fume Zero Halogen (LSFOH), Phosphorus Free polymeric liner for increased cable protection
- Designed, tested and manufactured in accordance with IEC 61914
- Consult Ellis for sizing

## Testing summary

Protect has been tested in line with the International Standard 'Cable Cleats for Electrical Installations' IEC 61914. Typical results are detailed below, please note that these testing values are maximums and safety factors appropriate to your application should be used:

PROPERTY	CLASSIFICATION CLAUSE IEC 61914	UNITS / CLASSIFICATION	TEST DATA
Cleat type	6.1.3	Composite	N/A
Temp. for permanent application	6.2	°C	-40 - +60
Corrosion resistance	6.5.2.2	High	316L stainless steel has ≥16% chromium
Impact rating	6.3.5	-	Refer to Ellis
Flame propagation test	10.0, 10.1	Application time ≥30s	Pass
Resistance to electromechanical force (short circuit testing)	6.4, 6.4.4, 9.5	Cleats at 300mm intervals (withstanding one short circuit)	133kA (Report No. PDL-18.071) Cable OD= Ø36mm

INTEGRITY

EXPERTISE

PRECISION

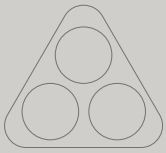

Trefoil formation  
**ATLAS™**  
 Galvanised steel

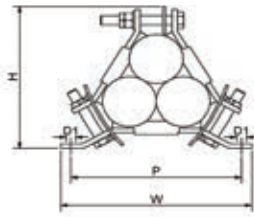

Two bolt base fixing

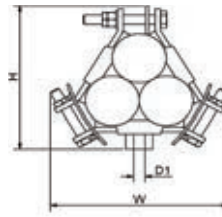

Single bolt base fixing

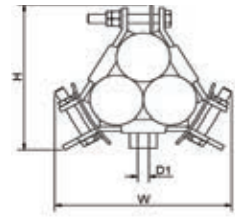

Framing channel base fixing



- Standard duty cable cleat for trefoil cable formation
- Cable range of Ø24mm – Ø102mm
- Galvanised steel frame with Low Smoke and Fume Zero Halogen (LSF0H), Phosphorus Free polymeric pads to protect the cable sheath
- Galvanised steel lower fixings and stainless steel top closure fixing to prevent eddy currents
- Fixing options: single bolt or two bolts
- Designed, tested and manufactured in accordance with IEC 61914

PART NO.	CABLE RANGE	DIMENSIONS (MM)									WEIGHT (G)
		TWO BOLT BASE FIXING					SINGLE BOLT BASE FIXING				
		W	H	D	P	FIXING HOLES (D1)	W	H	D	FIXING HOLES (D1)	
AR2-A31-XX	24-26	170	121	54	150	2 x M10	144	130	54	1 x M10	930
AR2-A32-XX	26-30	170	122	54	150	2 x M10	144	130	54	1 x M10	930
AR2-A33-XX	30-35	170	133	54	150	2 x M10	157	141	54	1 x M10	970
AR2-A34-XX	35-40	170	134	54	150	2 x M10	158	142	54	1 x M10	930
AR3-A35-XX	40-45	198	158	54	175	2 x M10	185	165	54	1 x M10	1200
AR3-A36-XX	45-50	198	160	54	175	2 x M10	187	167	54	1 x M10	1200
AR4-A37-XX	50-55	224	174	54	200	2 x M10	204	182	54	1 x M12	1300
AR4-A38-XX	55-60	224	179	54	200	2 x M10	210	187	54	1 x M12	1300
AR4-A39-XX	60-66	224	185	54	200	2 x M10	217	193	54	1 x M12	1300
AR5-A61-XX	66-71	250	225	54	225	2 x M10	254	225	54	1 x M12	1800
AR5-A62-XX	71-76	250	226	54	225	2 x M10	255	226	54	1 x M12	1800
AR5-A63-XX	76-82	250	230	54	225	2 x M10	260	230	54	1 x M12	1800
AR8-A64-XX	82-92	285	250	54	225	2 x M10	N/A			2100	
AR8-A65-XX	92-102	285	250	54	225	2 x M10	N/A			1900	

For full part number please replace 'XX' with the following.:  
 TB = Two bolt base fixing  
 SB = Single bolt base fixing

## Testing summary

Atlas Cleats have been tested in line with the International Standard 'Cable Cleats for Electrical Installations' IEC61914. Typical results are detailed below, please note that these testing values are maximums and safety factors appropriate to your application should be used:

PROPERTY	CLASSIFICATION CLAUSE IEC 61914	UNITS / CLASSIFICATION	TEST DATA
Cleat type	6.1.3	Composite	-
Temp. for permanent application	6.2	°C	-40 to +60
Impact rating	6.3.5	Very heavy	Pass
Flame propagation test	10.0, 10.1	Application time $\geq$ 30s	Pass
Axial load rating	6.4.3, 9.4	Newtons (N)	Refer to Ellis
Lateral load rating	6.4.2, 9.3	Newtons (N)	Refer to Ellis
Resistance to electromechanical force (short circuit testing)	6.4, 6.4.4, 9.5	Cleats at 300mm intervals (withstanding one short circuit)	120kA (Report No. PDL-18.122.7) Cable OD= Ø36mm

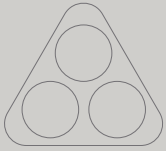

# Trefoil formation

## ALPHA™

### Aluminium

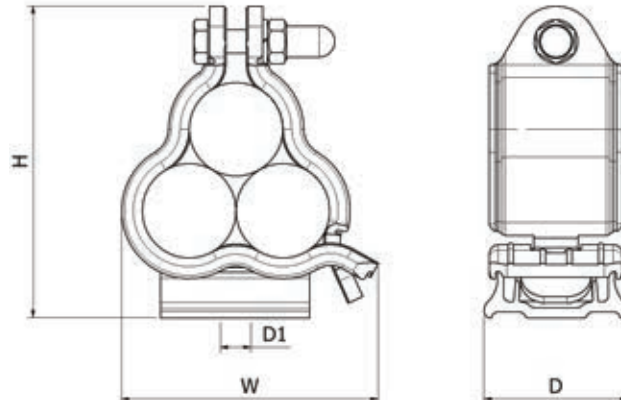

- Light duty cable cleat for trefoil cable formation
- Cable ranges of Ø23.2mm – Ø74.6mm
- 6000 series extruded aluminium with zinc-plated steel closure bolt
- Optional Low Smoke and Fume Zero Halogen (LSFOH), Phosphorus Free polymeric base available, to mitigate galvanic corrosion
- Optional polyester coating available for harsh or corrosive environments
- Single cable variants available on request
- Fixing options: one M10 fixing
- ABS approved and UL listed
- Designed, tested and manufactured in accordance with IEC 61914

PART NO. ALUMINIUM BASE	PART NO. POLYMER BASE	CABLE RANGE TREFOIL		DIMENSIONS (MM)				WEIGHT (G)
		MIN Ø (MM)	MAX Ø (MM)	W	H	D	FIXING HOLES (D1)	
ALP01-AN0	ALP01-AN1	23.2	25.1	76	93	48.5	1 x M10	168
ALP02-AN0	ALP02-AN1	25.1	27.1	79	96	48.5	1 x M10	178
ALP03-AN0	ALP03-AN1	27.1	29.3	82	101	48.5	1 x M10	185
ALP04-AN0	ALP04-AN1	29.3	31.7	86	105	48.5	1 x M10	195
ALP05-AN0	ALP05-AN1	31.7	34.2	91	110	48.5	1 x M10	205
ALP06-AN0	ALP06-AN1	34.2	37.0	96	116	48.5	1 x M10	217
ALP07-AN0	ALP07-AN1	37.0	40.0	101	121	48.5	1 x M10	229
ALP08-AN0	ALP08-AN1	40.0	43.2	106	127	48.5	1 x M10	241
ALP09-AN0	ALP09-AN1	43.2	46.7	113	134	48.5	1 x M10	255
ALP10-AN0	ALP10-AN1	46.7	50.5	119	141	48.5	1 x M10	272
ALP11-AN0	ALP11-AN1	50.5	54.6	127	148	48.5	1 x M10	288
ALP12-AN0	ALP12-AN1	54.6	59.0	135	156	48.5	1 x M10	307
ALP13-AN0	ALP13-AN1	59.0	63.8	144	165	48.5	1 x M10	327
ALP14-AN0	ALP14-AN1	63.8	69.0	153	175	48.5	1 x M10	348
ALP15-AN0	ALP15-AN1	69.0	74.6	163	186	48.5	1 x M10	372



Polymer Base  
(With Polyester Coated Frame)



Aluminium Base

## Testing summary

Alpha Cleats have been tested in line with the International Standard 'Cable Cleats for Electrical Installations' IEC 61914. Typical results are detailed below, please note that these testing values are maximums and safety factors appropriate to your application should be used:

PROPERTY	CLASSIFICATION CLAUSE IEC 61914	UNITS / CLASSIFICATION	TEST DATA
Cleat type	6.1.1, 6.1.3	Metallic / composite	-
Temp. for permanent application	6.2	°C	-40 to +60
UV resistance	6.5.1	Xenon arc method A	Pass Applicable to powder coated and polymer base options
Corrosion resistance	6.5.2	Refer to Ellis	Refer to Ellis
Impact rating	6.3.5	Very heavy	Pass
Flame propagation test	10.0, 10.1	Application time $\geq 30s$	Pass
Axial load rating	6.4.3, 9.4	Newtons (N)	Refer to Ellis
Lateral load rating	6.4.2, 9.3	Newtons (N)	Horizontal - 500N Vertical - 500N
Resistance to electromechanical force (short circuit testing)	6.4, 6.4.4, 9.5	Cleats at 300mm intervals (withstanding one short circuit)	84.7kA (Report No. LCOE 2025 09 35 0695-5) Cable OD = $\varnothing 35.5mm$
Resistance to electromechanical force (short circuit testing)	6.4, 6.4.5, 9.5	Cleats at 600mm intervals (withstanding more than one short circuit)	74.5kA (Report No. LCOE 2025 09 35 0695-5) Cable OD = $\varnothing 35.4mm$



Lateral load:  
vertical direction

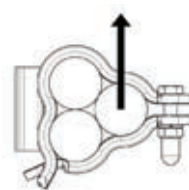

Lateral load:  
horizontal direction



Conduit & cable hardware 4CG8 with  
AH-2 & wet locations. Listed sizes:  
ALP01-AN0 to ALP15-AN0.

LONDON UNDERGROUND  
Alpha Cable Cleats are compliant with  
the requirements of LUL-1085. Product  
register number 360.

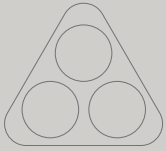

## Trefoil formation CENTAUR™ TREFOIL Aluminium

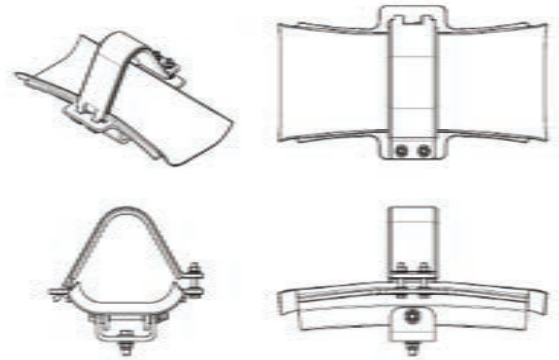

- Heavy duty cable saddle for trefoil cable formation
- Specially designed for High Voltage, sagged cable systems
- Curved saddle accommodates cable thermal expansion and sag
- Flared edges prevent cable damage
- Project specific design, built to a specified cable diameter (Ø)
- Available in standard lengths of 400, 600 and 800mm to allow for different cable diameters and mounting centres.
- Non-standard lengths available on request
- 6000 series aluminium
- A4-70 stainless steel closure fixings with isolation washers to prevent galvanic corrosion
- Low Smoke and Fume Zero Halogen (LSFOH), Phosphorus Free polymeric liner, incorporated into the over-strap, for increased cable protection
- Designed, tested and manufactured in accordance with IEC 61914

Centaur Trefoil cable saddles are designed to support HV cables in trefoil formations alongside steelwork centres typically around 3 - 8m.

The assembly consists of an extruded and pressed aluminium saddle and a hinged aluminium overstrap. The curvature of the saddle accommodates the thermal expansion of the cable and the ends of the saddle are flared so that the cable never comes into contact with a sharp edge under any circumstances.

Centaur Trefoil is available in lengths of 400, 600 and 800mm to allow for different cable diameters and mounting centres.

Centaur Trefoil is project specific. Please contact Ellis for further details.



A photo of the short circuit test rig for centaur trefoil including flexi-straps. Testing was carried out at ZKU Laboratories in Prague, CZ.

## Testing summary

Centaur cable saddles have been tested in line with the International Standard 'Cable Cleats for Electrical Installations'. As IEC 61914 is part of the low voltage directive it is not possible to follow the standard exactly and thus deviations have been made in areas. Typical results are detailed below, please note that these testing values are maximums and safety factors appropriate to your application should be used:

PROPERTY	CLASSIFICATION CLAUSE IEC 61914	UNITS / CLASSIFICATION	TEST DATA
Cleat type	6.1.3	Composite	-
Temp. for permanent application	6.2	°C	-40 to +60
UV resistance	6.5.1.2	UV resistant	Metallic frame shields all polymer components
Corrosion resistance	6.5.2.2	Refer to Ellis	-
Impact rating	6.3.5	Very heavy	Pass
Flame propagation test	10.0, 10.1	Application time $\geq 30s$	Pass
Axial load rating	6.4.3, 9.4	Newtons (N)	Refer to Ellis
Lateral load rating	6.4.2, 9.3	Newtons (N)	Refer to Ellis
Resistance to electromechanical force (short circuit testing)	6.4, 6.4.4, 9.5	Centaur Cleats at 7m with straps at 1m	117kA (Report No. ZKU 16-051) Cable=Ø140mm

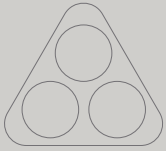

Trefoil formation

# CENTAUR™ SPACED INTERMEDIATE STRAP

Aluminium



- Heavy duty intermediate strap, for use in conjunction with the Centaur® Single cable saddle, when installed in a spaced-out trefoil formation
- Specially designed for High Voltage, snaked cable systems
- Maintains phase spacing between single cables and offers additional short circuit restraint
- Project specific design, built to a specified cable diameter (Ø)
- 6000 series aluminium
- Designed, tested and manufactured in accordance with IEC 61914
- Please consult Ellis for size and spacing availability

## Testing summary

Centaur Spaced Intermediate Straps have been tested in line with the International Standard 'Cable Cleats for Electrical Installations'. As IEC 61914 is part of the low voltage directive it is not possible to follow the standard exactly and thus deviations have been made in areas. Typical results are detailed below, please note that these testing values are maximums and safety factors appropriate to your application should be used:

PROPERTY	CLASSIFICATION CLAUSE IEC 61914	UNITS / CLASSIFICATION	TEST DATA
Cleat type	6.1.3	Composite	-
Temp. for permanent application	6.2	°C	-40 to +60
UV resistance	6.5.1.2	UV resistant	Metallic frame shields all polymer components
Corrosion resistance	6.5.2.2	Refer to Ellis	-
Impact rating	6.3.5	Very heavy	Pass
Flame propagation test	10.0, 10.1	Application time ≥30s	Pass
Axial load rating	6.4.3, 9.4	Newtons (N)	Refer to Ellis
Lateral load rating	6.4.2, 9.3	Newtons (N)	Refer to Ellis
Resistance to electromechanical force (short circuit testing)	6.4, 6.4.4, 9.5	227kA (Report No. 2024.10.35.0745) Cable = Ø58mm 270MM phase spacing @1.2M Spacing calculated force 39,420N	

TRIED

TESTED

TRUSTED

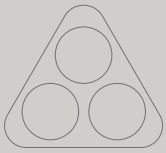

# Trefoil formation TRIDENT™ Polymer

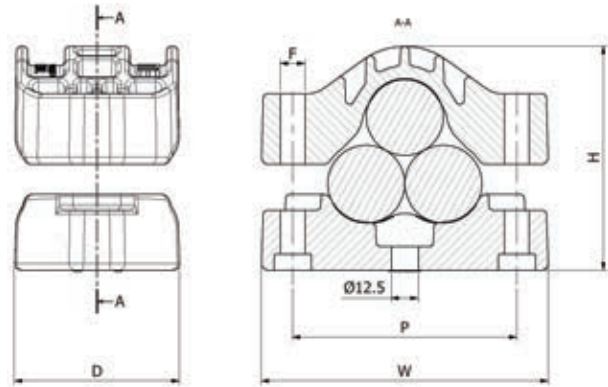

- Standard duty cable cleat for trefoil cable formation
- Range-taking design ensures true trefoil formation across all sizes
- Cable range of Ø24mm – Ø83mm
- Available in two materials; Low Smoke and Fume Zero Halogen (LSF0H), Phosphorus Free Nylon or Glass Filled Nylon suitable for higher temperature applications (-60°C to +120°C, UL94 V-0)
- Fixing options: Single or Twin Bolt fixing options, sizing shown in table below. Fixings are not supplied as standard but are available on request
- Designed, tested and manufactured in accordance with IEC 61914

PART NO.	CABLE RANGE		DIMENSIONS (MM)					GFN WEIGHT (G)	LSF WEIGHT (G)
	MIN Ø (MM)	MAX Ø (MM)	W	H	D	P	F		
TR24-29XXX	24	29	122	91	77	92.5	M10	360	288
TR27-32XXX	27	32	126	95	77	98.5	M10	370	296
TR30-36XXX	30	36	134	104	77	104.5	M10	383	306
TR34-41XXX	34	41	144	112	77	114.5	M10	485	388
TR39-47XXX	39	47	156	124	77	125	M12	568	454
TR45-54XXX	45	54	172	138	77	145	M12	666	533
TR52-62XXX	52	62	190	153	77	160	M12	793	634
TR60-72XXX	60	72	215	177	98	182	M12	1100	880
TR69-83XXX	69	83	238	198	98	205	M12	1300	1040

Where ':XXX' add the material required either GFN or LSF

## Large cable alternatives

For larger cable Ø please see Colossus on page 70 as an alternative polymeric trefoil cleat

## Testing summary

Trident Cleats have been tested in line with the International Standard 'Cable Cleats for Electrical Installations' IEC61914. Typical results are detailed below, please note that these testing values are maximums and safety factors appropriate to your application should be used:

PROPERTY	CLASSIFICATION CLAUSE IEC 61914	UNITS / CLASSIFICATION	GFN TEST DATA	LSF TEST DATA
Cleat type	6.1.2	Non-metallic	-	-
Temp. for permanent application	6.2	°C	-40 - +120	-60 to +60
UV resistance	6.5.1.2	Xenon arc method A	Pass	Pass
Corrosion resistance	6.5.2	N/A	N/A	N/A
Impact rating	6.3.5	Very heavy/heavy	Pass	Heavy
Flame propagation test	10.0, 10.1	Application time $\geq 30s$	Pass	Pass
Axial load rating	6.4.3, 9.4	Newtons (N)	1100N	1500N
Lateral load rating	6.4.2, 9.3	Newtons (N)	Horizontal - 2,250N Vertical -2,250N	Horizontal - 2,250N Vertical -2,250N
Resistance to electromechanical force (short circuit testing)	6.4, 6.4.5, 9.5	cleats at 300mm intervals (withstanding more than one short circuit)	134kA (Report No. PDL-18.071.6) Cable OD= $\varnothing 36mm$	121kA (Report No. PDL-22.159.2) Cable OD= $\varnothing 36mm$
Resistance to electromechanical force (short circuit testing)	6.4, 6.4.5, 9.5	cleats at 600mm intervals (withstanding more than one short circuit)	94kA (Report No. PDL-18.071.5) Cable OD= $\varnothing 36mm$	107.7kA (Report No. LCOE 2025 09 3S 0695-12) Cable OD= $\varnothing 36mm$

1) Results obtained using 2x M10 316L A4-70 grade stainless steel fixings

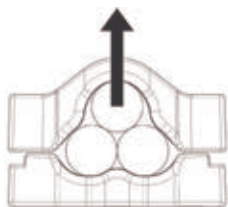

Lateral load:  
vertical direction



Lateral load:  
horizontal direction

Twin fixing

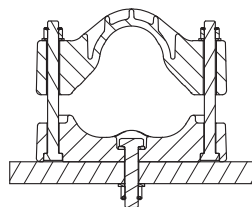
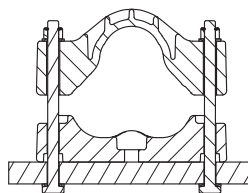

Single fixing

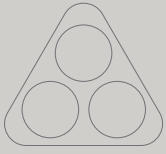

# Trefoil formation TRIDENT™ WITH SPACER Polymer

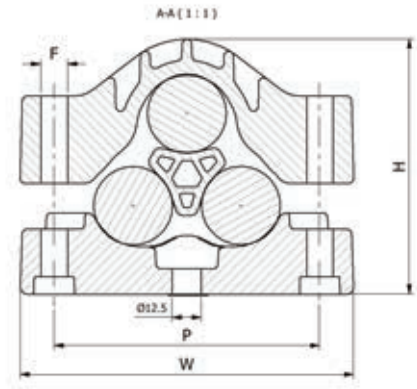
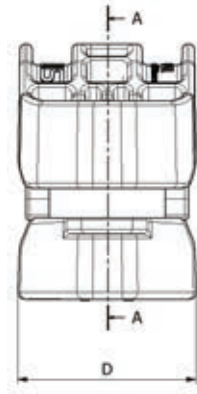

- Standard duty cable cleat for spaced trefoil cable formation
- The spacer piece ensures an equidistant cable spacing whilst providing a larger clamp range
- Cable range of Ø29mm – Ø54mm
- Low Smoke and Fume Zero Halogen (LSF0H), Phosphorus Free Nylon
- Fixing options: Single or Twin Bolt fixing options, sizing shown in table below. Fixings are not supplied as standard but are available on request
- Designed, tested and manufactured in accordance with IEC 61914

PART NO.	CABLE RANGE WITH SPACER		CABLE RANGE WITHOUT SPACER		DIMENSIONS (MM)					WEIGHT (G)	CORRESPONDING TRIDENT
	MIN Ø (MM)	MAX Ø (MM)	MIN Ø (MM)	MAX Ø (MM)	W	H	D	P	F		
TR29-41SP	29	34	34	41	144	115	77	114.5	M10	530	TR34-41
TR33-47SP	33	39	39	47	156	127	77	125	M12	618	TR39-47
TR41-54SP	41	45	45	54	172	141	77	145	M12	706	TR45-54

Note: removal of the spacer piece can be utilised to provide a product with a large range take. Refer to standard trident data sheet.

## Testing summary

Trident Cleats have been tested in line with the International Standard 'Cable Cleats for Electrical Installations' IEC 61914. Typical results are detailed below, please note that these testing values are maximums and safety factors appropriate to your application should be used:

PROPERTY	CLASSIFICATION CLAUSE IEC 61914	UNITS / CLASSIFICATION	TEST DATA
Cleat type	6.1.2	Non-metallic	-
Temp. for permanent application	6.2	°C	-40 to +120
UV resistance	6.5.1.2	Xenon arc method A	Pass
Corrosion resistance	6.5.2	N/A	N/A
Impact rating	6.3.5	Very heavy	Heavy
Flame propagation test	10.0, 10.1	Application time ≥30s	Pass
Axial load rating	6.4.3, 9.4	Newtons (N)	Refer to Ellis
Lateral load rating	6.4.2, 9.3	Newtons (N)	Refer to Ellis
Resistance to electromechanical force (Short circuit testing)	6.4, 6.4.5, 9.5	Cleats at 300mm intervals (withstanding more than one short circuit)	106kA (Report No. PDL-21.085.3)  Cable OD= Ø36mm Cable spacing = 50mm

# QUAD CABLE FORMATION

Ellis quad cable cleats are designed to securely retain and support cables installed in quad formation, providing controlled cable management and mechanical stability in high-density installations. This configuration is commonly specified in critical environments such as data centres and commercial infrastructure, where continuity of service and system uptime are paramount.

To support efficient installation across a variety of containment systems, Ellis' quad cable cleats can be supplied with alternative fixing solutions for applications where traditional fixing points are not available. Options such as clamp-based fixings allow secure attachment to cable tray or ladder rungs, enabling compliant installations without the need for drilling or modification to existing support structures.

The quad range accommodates a wide selection of cable diameters and quadruplex constructions and is available in multiple material options to suit environmental, mechanical and regulatory requirements. This ensures dependable long-term performance, installation flexibility and compatibility with a broad range of project specifications.

## QUAD CABLE FORMATION

Stainless steel	
Vulcan+ Quad	80
Vulcan+ Quad Twist-Foot	82
Emperor™ Quad	84
Emperor™ Quad - Twist-Foot	86

## MULTIPLE / COMPLEX CABLE FORMATION

Polymer	
Matrix	88

The data sheets are subject to change without notice. The information provided has been generated in laboratory conditions, as such results in use may vary.

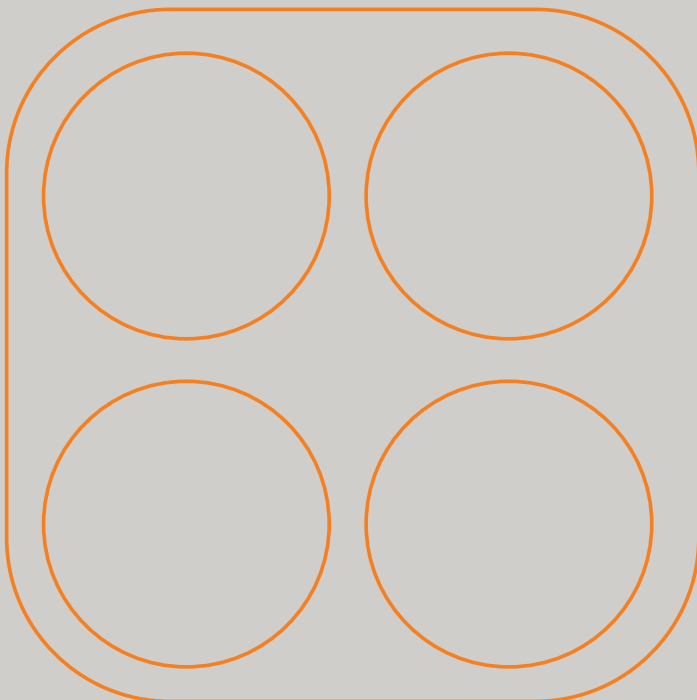



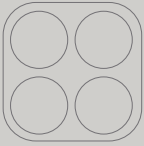

# Quad cable formation VULCAN+™ QUAD

Stainless steel

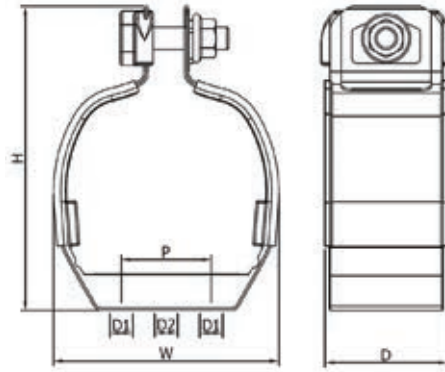

- Standard duty cable cleat for quad cable formation
- Cable range of Ø10mm – Ø70mm
- 316L stainless steel frame with A4-70 stainless steel captive closure fixings
- Low Smoke and Fume Zero Halogen (LSFOH), Phosphorus Free polymeric liners for increased cable protection
- Fixing options: one or two M10 fixings (cleat size dependent as listed in table)
- ABS type approved and UL listed
- Designed, tested and manufactured in accordance with IEC 61914

PART NO.	CABLE RANGE		DIMENSIONS (MM)					WEIGHT (G)
	MIN Ø (MM)	MAX Ø (MM)	W	H	D	P	FIXING HOLES (D1)	
VRQ+00C	10	13	63	93	54	N/A	1 x M10	287
VRQ+00B	13	18	67	97	54	N/A	1 x M10	280
VRQ+00A	18	20	70	106	54	N/A	1 x M10	291
VRQ+00	19	23	74	113	54	N/A	1 x M10	317
VRQ+01	23	25	68	110	54	N/A	1 x M10	284
VRQ+02	26	27	70	113	54	N/A	1 x M10	286
VRQ+03	28	31	78	128	54	N/A	1 x M10	318
VRQ+03A	31	35	90	138	54	N/A	1 x M10	326
VRQ+04	35	42	103	148	54	N/A	1 x M10	378
VRQ+05	43	47	120	165	54	N/A	1 x M10	452
VRQ+06	48	50	121	170	54	N/A	1 x M10	467
VRQ+07	51	57	140	190	54	N/A	1 x M10	523
VRQ+08	58	63	150	200	54	50	3 x M10	541
VRQ+09	64	70	170	218	54	50	3 x M10	581

## Testing summary

Vulcan+ Cleats have been tested in line with the International Standard 'Cable Cleats for Electrical Installations' IEC 61914. Typical results are detailed below, please note that these testing values are maximums and safety factors appropriate to your application should be used:

PROPERTY	CLASSIFICATION CLAUSE IEC 61914	UNITS / CLASSIFICATION	TEST DATA
Cleat type	6.1.3	Composite	-
Temp. for permanent application	6.2	°C	-40 to +60
UV resistance	6.5.1.2	Xenon arc method A	Pass
Corrosion resistance	6.5.2.2	High	316L stainless steel HAS≥16% chromium
Impact rating	6.3.4	Very heavy	Pass
Flame propagation test	10.0, 10.1	Application time ≥30s	Pass
Axial load rating	6.4.3, 9.4	Newtons (N)	100N
Lateral load rating	6.4.2, 9.3	Newtons (N)	Horizontal - 100N Vertical -350N
Resistance to electromechanical force (short circuit testing)	6.4, 6.4.5, 9.5	Cleats at 300mm intervals (withstanding more than one short circuit)	134kA (Report No. PDL-22.079.03) Cable OD= Ø36mm
Resistance to electromechanical force (short circuit testing)	6.4, 6.4.5, 9.5	Cleats at 600mm intervals (withstanding more than one short circuit)	119kA (Report No. LCOE 2025 05 35 0317-7) Cable OD= Ø37.5mm



Lateral load:  
vertical direction

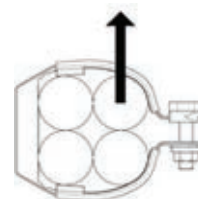

Lateral load:  
horizontal direction



Conduit & cable hardware 4CG8 with  
AH-2 & wet locations. Listed sizes:  
VRQ+01 to VRQ+09.

LONDON UNDERGROUND  
Vulcan+ Cable Cleats are compliant  
with the requirements of LUL-1085.  
Product register number 361.

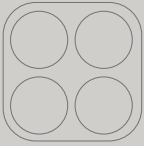

Quad cable formation

# VULCAN+™ QUAD TWIST FOOT

Stainless steel

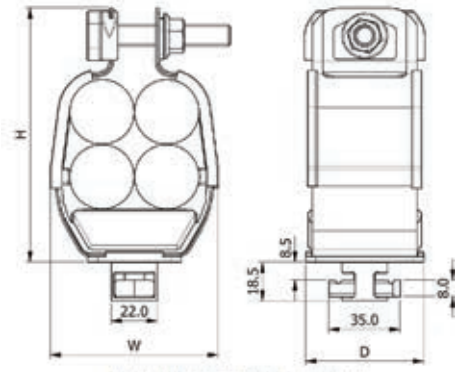

- Vulcan+™ Quad cable cleat supplied with integrated Twist-Foot base fixing kit
- Designed for rapid installation into 41×41mm and 41×21mm unistrut channel or ladder with inverted rungs
- All fixings supplied pre-assembled – no additional site fixings required
- Standard duty cable cleat for quad cable formation
- Cable range of Ø10mm – Ø70mm
- Single-foot versions for cable range Ø10mm - Ø63mm
- Fixing kits available in A4 stainless steel, galvanised steel or zinc-plated steel
- Designed, tested and manufactured in accordance with IEC 61914

PART NO.	CABLE RANGE QUAD		DIMENSIONS (MM)			WEIGHT (G)
	MIN Ø (MM)	MAX Ø (MM)	W	H	D	
VRQ+00CTFM10-X	10	13	63	96	54	337
VRQ+00BTFM10-X	13	18	67	100	54	330
VRQ+00ATFM10-X	18	20	70	109	54	341
VRQ+00TFM10-X	19	25	74	116	54	367
VRQ+01TFM10-X	23	25	68	113	54	334
VRQ+02TFM10-X	26	27	70	116	54	336
VRQ+03TFM10-X	28	31	78	131	54	368
VRQ+03ATFM10-X	31	35	90	141	54	376
VRQ+04TFM10-X	35	42	103	151	54	428
VRQ+05TFM10-X	43	47	120	168	54	502
VRQ+06TFM10-X	48	50	121	173	54	517
VRQ+07TFM10-X	51	57	140	193	54	573
VRQ+08TFM10-X	58	63	150	203	54	591
VRQ+09TFM10-X	64	70	170	221	54	631

'x' denotes fixing material, options are as follows:

4 = A4 stainless steel

G = galvanised steel

Z = zinc plated steel

e.g A VRQ+04 with stainless steel twist foot fixings becomes: VRQ+04TFM10-4

## Testing summary

Vulcan+ Cleats have been tested in line with the International Standard 'Cable Cleats for Electrical Installations' IEC 61914. Typical results are detailed below, please note that these testing values are maximums and safety factors appropriate to your application should be used:

PROPERTY	CLASSIFICATION CLAUSE IEC 61914	UNITS / CLASSIFICATION	TEST DATA
Cleat type	6.1.3	Composite	-
Temp. for permanent application	6.2	°C	-40 to +60
UV resistance	6.5.1.2	Xenon arc method A	Pass
Corrosion resistance	6.5.2.2	High	316L stainless steel HAS≥16% chromium
Impact rating	6.3.4	Very heavy	Pass
Flame propagation test	10.0, 10.1	Application time ≥30s	Pass
Axial load rating	6.4.3, 9.4	Newtons (N)	100N
Lateral load rating	6.4.2, 9.3	Newtons (N)	Horizontal - 100N Vertical -350N
Resistance to electromechanical force (short circuit testing)	6.4, 6.4.5, 9.5	Cleats at 300mm intervals (withstanding more than one short circuit)	134kA (Report No. PDL-22.079.03) Cable OD= Ø36mm
Resistance to electromechanical force (short circuit testing)	6.4, 6.4.5, 9.5	Cleats at 600mm intervals (withstanding more than one short circuit)	119kA (Report No. LCOE 2025 05 35 0317-7) Cable OD= Ø37.5mm

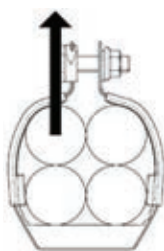

Lateral load:  
vertical direction

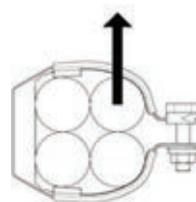

Lateral load:  
horizontal direction



Click to see how  
easy the Twist-Foot  
is to install.

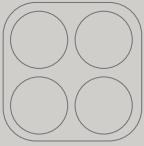

Quad cable formation  
**EMPEROR™ QUAD**  
 Stainless steel

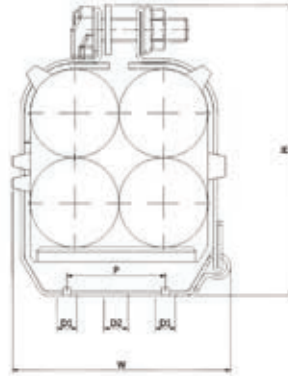

- Heavy duty cable cleat for quad formation
- Cable range of Ø19mm – Ø49mm
- 316L stainless steel frame with A4-70 stainless steel captive closure fixings
- Low Smoke and Fume Zero Halogen (LSFOH), Phosphorus Free polymeric liners for increased cable protection
- Fixing options: two M10 fixings or one M12 fixing
- Designed, tested and manufactured in accordance with IEC 61914

PART NO.	CABLE RANGE		DIMENSIONS (MM)					WEIGHT (G)
	MIN Ø (MM)	MAX Ø (MM)	W	H	D	P	FIXING HOLES (D1 & D2)	
EQ19-24	19	24	78.5	107	54	25	2 x M10 + 1 x M12	552
EQ24-28	24	28	78.5	107	54	25	2 x M10 + 1 x M12	423
EQ26-30	26	30	79	113	54	25	2 x M10 + 1 x M12	451
EQ31-36	31	36	92	133	54	25	2 x M10 + 1 x M12	620
EQ36-40	36	40	92	133	54	25	2 x M10 + 1 x M12	495
EQ40-45	40	45	111	147	54	50	2 x M10 + 1 x M12	773
EQ44-49	44	49	111	147	54	50	2 x M10 + 1 x M12	684

## Testing summary

Emperor Cleats have been tested in line with the International Standard 'Cable Cleats for Electrical Installations' IEC 61914. Typical results are detailed below, please note that these testing values are maximums and safety factors appropriate to your application should be used:

PROPERTY	CLASSIFICATION CLAUSE IEC 61914	UNITS / CLASSIFICATION	TEST DATA
Cleat type	6.1.3	Composite	
Temp. for permanent application	6.2	°C	-40 to +60
Corrosion resistance	6.5.2.3	Outdoor	316L stainless steel has ≥16% chromium
Impact rating	6.3.5	Very heavy	Pass
Flame propagation test	10.1	Application time ≥30s	Pass
Axial load rating	6.4.3, 9.4	Newtons (N)	300N
Lateral load rating	6.4.2, 9.3.1	Newtons (N)	Horizontal - 650N Vertical - 1000N
Resistance to electromechanical force (Short circuit testing)	6.4.4, 9.5	Cleats at 300mm intervals (withstanding one short circuit)	195kA (REPORT No. PDL-09.098.2) Cable OD= Ø38mm
Resistance to electromechanical force (Short circuit testing)	6.4.5, 9.5	Cleats at 600mm intervals (withstanding more than one short circuit)	157.8kA (Report No. 2024 10 35 07454) Cable OD= Ø37.5mm

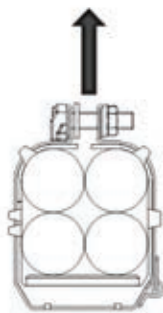

Lateral load:  
vertical direction

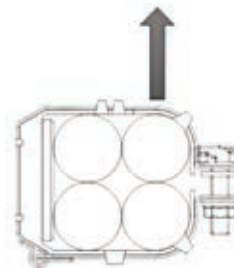

Lateral load:  
horizontal direction

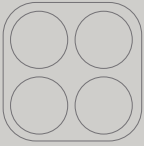

Quad cable formation

# EMPEROR™ QUAD TWIST FOOT

Stainless steel

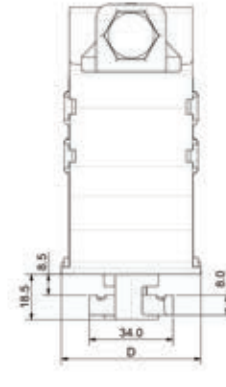
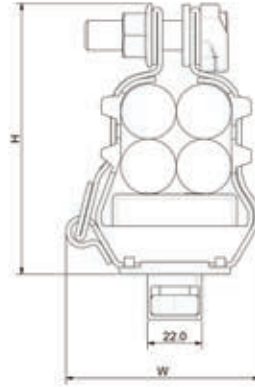

- Emperor™ Quad cable cleat supplied with an integrated Twist-Foot base fixing kit
- Designed for rapid installation into 41×41 and 41×21 unistrut channel or ladder with inverted rungs
- All fixings supplied pre-assembled – no additional site fixings required
- Heavy duty cable cleat for quad cable formation
- Cable range of Ø19mm – Ø49mm
- 316L stainless steel frame with A4-70 stainless steel captive closure fixings
- Low Smoke and Fume Zero Halogen (LSFOH), Phosphorus Free polymeric liners for increased cable protection
- Single-foot twist-foot base for all size
- Fixing kits available in A4 stainless steel, galvanised steel or zinc-plated steel
- Designed, tested and manufactured in accordance with IEC 61914

PART NO.	CABLE RANGE QUAD		DIMENSIONS (MM)			WEIGHT (G)
	MIN Ø (MM)	MAX Ø (MM)	W	H	D	
EQ19-24TFM12-X	19	24	78.5	110	54	628
EQ24-28TFM12-X	24	28	78.5	110	54	499
EQ26-30TFM12-X	26	30	79	116	54	527
EQ31-36TFM12-X	31	36	92	136	54	696
EQ36-40TFM12-X	36	40	92	136	54	571
EQ40-45TFM12-X	40	45	111	150	54	849
EQ44-49TFM12-X	44	49	111	150	54	760

X denotes fixing material, options are as follows:

- 4 = A4 Stainless steel
- G = Galvanised steel
- Z = Zinc plated steel

e.g A EQ19-24 with stainless steel twist foot fixings becomes: EQ19-24TFM12-4

## Testing summary

Emperor Cleats have been tested in line with the International Standard 'Cable Cleats for Electrical Installations' IEC 61914. Typical results are detailed below, please note that these testing values are maximums and safety factors appropriate to your application should be used:

PROPERTY	CLASSIFICATION CLAUSE IEC 61914	UNITS / CLASSIFICATION	TEST DATA
Cleat type	6.1.3	Composite	
Temp. for permanent application	6.2	°C	-40 to +60
Corrosion resistance	6.5.2.3	Outdoor	316L stainless steel has ≥16% chromium
Impact rating	6.3.5	Very heavy	Pass
Flame propagation test	10.1	Application time ≥30s	Pass
Axial load rating	6.4.3, 9.4	Newtons (N)	300N
Lateral load rating	6.4.2, 9.3.1	Newtons (N)	Horizontal - 650N Vertical - 1000N
Resistance to electromechanical force (Short circuit testing)	6.4.4, 9.5	Cleats at 300mm intervals (withstanding one short circuit)	195kA (Report No. PDL-09.098.2) Cable OD= Ø38mm
Resistance to electromechanical force (Short circuit testing)	6.4.5, 9.5	Cleats at 600mm intervals (withstanding more than one short circuit)	157.8kA (Report No. 2024 10 35 07454) Cable OD= Ø37.5mm

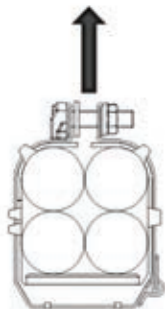

Lateral load:  
vertical direction

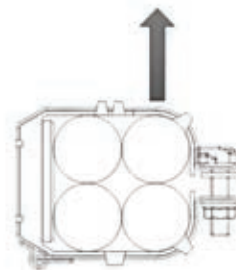

Lateral load:  
horizontal direction



Click to see how easy the Twist-Foot is to install.

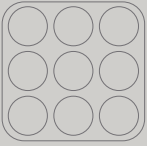

# Multiple cable formation

## MATRIX™

Polymer

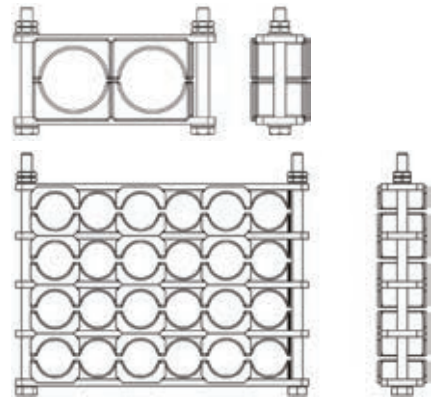

- Light Duty Galvanised Steel & Polymer Cable Cleat for multiple cables
- Cleat design allows multiple cables to be assembled in a matrix style
- For cables ranges Ø20–70mm
- Hot-dipped galvanised steel frame
- Low Smoke and Fume Zero Halogen (LSF0H), Phosphorus Free polymeric pads for increased cable protection
- Closure fixing: A4-70 stainless steel
- Designed, tested and manufactured in accordance with IEC 61914

### Testing summary

Matrix has been tested in line with the International Standard 'Cable Cleats for Electrical Installations' IEC 61914. Typical results are detailed below, please note that these testing values are maximums and safety factors appropriate to your application should be used:

PROPERTY	CLASSIFICATION CLAUSE IEC 61914	UNITS / CLASSIFICATION	TEST DATA
Cleat type	6.1.3	Composite	
Temp. For permanent application	6.2	°C	-40 to +60
UV resistance	6.5.1.2	Refer to Ellis	
Impact rating	6.3.5	Very heavy	Pass
Flame propagation test	10.0, 10.1	Application time ≥30s	Pass
Axial load rating	6.4.3, 9.4	Newtons (N)	Refer to Ellis
Lateral load rating	6.4.2, 9.3	Newtons (N)	Refer to Ellis
Resistance to electromechanical force (short circuit testing)	6.4, 6.4.4, 9.5	Cleats at 300mm intervals (withstanding more than one short circuit)	91.3kA (Report No. PDL-18.071.2) Phase spacing = Ø45mm (MC-4x1-037-G)

## FIXINGS & ACCESSORIES



We offer a wide range of cable cleats which are in turn attached to an array of different mounting structures on site.

Purchasing mounting fixings alongside cleats helps to:

- Reduce purchase burden
- Lower risk of errors in specification
- Lessen logistical management onsite



Our Fixings Calculator will help you determine the correct mounting fixings for the cable cleats you order.

Visit

[www.ellispatents.co.uk/products/fixings/fixings-calculator](http://www.ellispatents.co.uk/products/fixings/fixings-calculator)

or scan the QR code to begin your calculation.

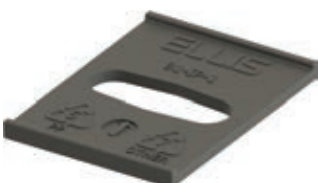

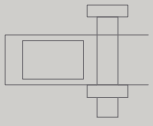

## Fixings & Accessories

# LADDER ADAPTORS

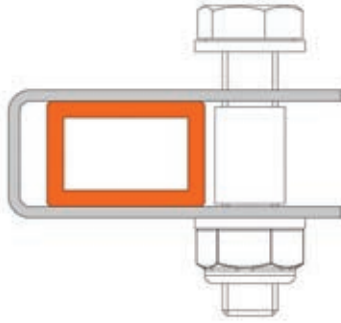

- Ladder adaptors are designed to fit Ellis cleats to a wide range of ladder rungs where no mounting slots or holes are provided
- Main body made from 316L stainless steel
- Supplied with fixings
- Available with M10 or M12 fixings

LADDER/STRUT/ MOUNTING SURFACE DIMENSIONS		ELLIS LADDER ADAPTOR PART NUMBER*				
		KIT0042-XXX	KIT0046-XXX	KIT0008-XXX	KIT0104-XXX	KIT0105-XXX
HEIGHT	INCHES	1/2	1	1	1/2	15/16
	MM	12.5	25.4	25.4	12.7	24
WIDTH	INCHES	1 1/2	1 5/8	1	2 1/8	2 1/8
	MM	38	41	25.4	54	54

Where 'XXX' add the fixings you require, either -M10 or -M12

### Do you need a different adaptor?

Ellis can manufacture ladder adaptors to suit any given dimensions, whether you need an adaptor to fit a round, D-rung or top hat shaped ladder rung we have the experience and expertise to deliver exactly what you need.

Simply contact us with your height (H) and width (W) requirements:  
[sales@ellispatents.co.uk](mailto:sales@ellispatents.co.uk)

Scan to contact us via our website





# Fixings & Accessories

## INSULATION PLATES

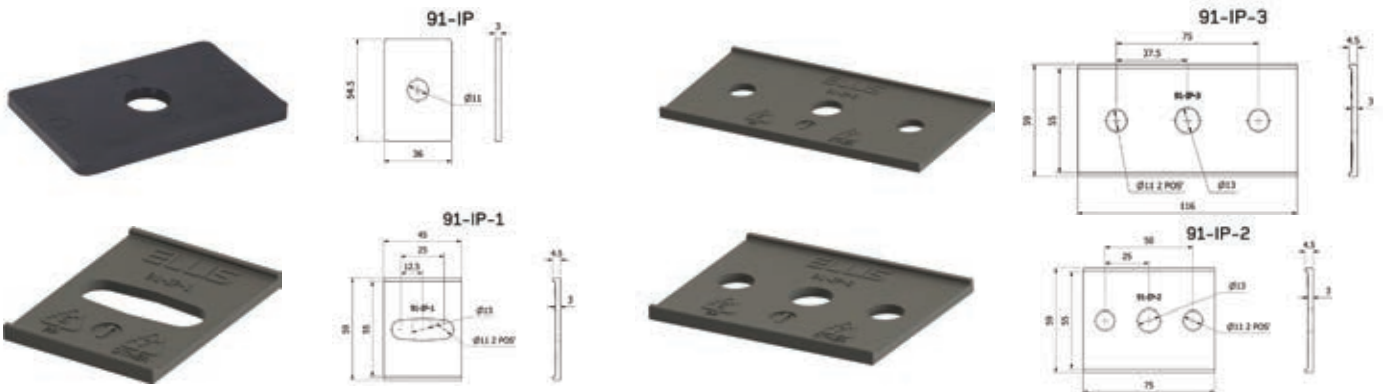

Insulation plates are typically used to break the electrical contact between dissimilar metals (e.g. fastening a stainless steel cleat onto a galvanised structure) and mitigate the risks of bi-metallic corrosion.

Ellis offers a range of insulation plates to suit different cleat sizes. The plates are manufactured as standard in black polypropylene or black flame retardant V0 zero halogen UV stabilised nylon (LSF).

Typical Cleat recommendations are as follows:

### Emperor

91-IP-1: ER19-23 to ER33-38 and ES32-39 to ES65-73 and EQ19-24 to EQ36-40

91-IP-2: ER36-42 to ER51-58 and ES73-85 to ES94-118 and EQ40-45 to EQ44-49

91-IP-3: ER55-62 to ER119-128 and ES118-130 to ES127-150

### Vulcan+

91-IP: VRT+00C to VRT+02 and VRQ+00C to VRQ+02

91-IP-1: VRT+03 to VRT+06 and VRQ+03 to VRQ+04

91-IP-2: VRT+07 to VRT+12 and VRQ+05 to VRQ+08

91-IP-3: VRT+13 to VRT+20 and VRQ+09



### SPECIFICATION

PART NO.	MATERIAL SUFFIX	PACK QTY	WEIGHT G
91-IP	B	100	5
91-IP12	B/LSF	100	5
91-IP-1	B/LSF	100	5
91-IP-2	B/LSF	100	5
91-IP-3	B/LSF	100	5

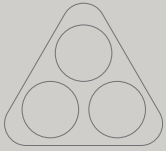

Trefoil formation

# TRIPLEX CABLE SURROUND

Polymer

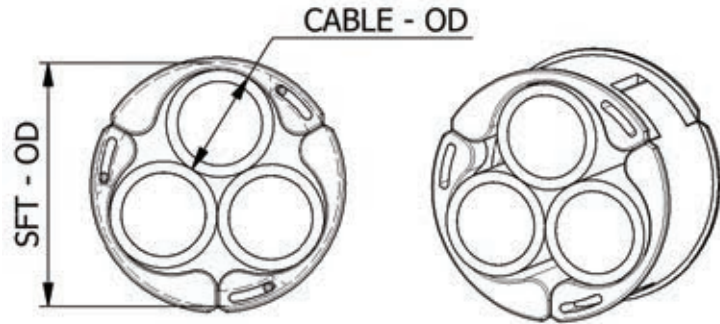

- An insert which can be utilised with the following products: Emperor™ Single, Vulcan+™, 2F+ Two Hole Cable Clamp or 2A Two Hole Cable Clamp
- Helps overcome the twist in triplex cable to allow the cable to be cleated at any point along its length
- Low Smoke and Fume Zero Halogen (LSFOH), Phosphorus Free Nylon

PART NO.	CABLE RANGE		DEPTH (MM)	WEIGHT (G)
	MIN	MAX		
SFT26	24	28	62	67.3
SFT31 / SFT2F+31	28	34	62 / 84	87 / 125
SFT36 / SFT2F+36	33	39	62 / 84	113 / 160
SFT43 / SFT2F+43	39	47	62 / 109	140 / 272
SFT51 / SFT2F+51	47	55	62 / 134	212 / 447

Note: SFT2F+XX part numbers refer to a deeper SFT+ moulding to be used with 2F+ and 2A clamps, see page 2 for more detail.

Note: 'cable range' refers to the outside diameter of one individual cable core within the triplex braid.

This product has been short circuit tested in line with EN 50368:

Configuration: 2F+LSF cleat with SFT

Peak current: 76KA

Cleat spacing: 600mm

Cable cleat selection detail for cleats to be used with the triplex cable surround

CABLE OD (MM)	SFT OD (MM)	ADAPTOR TYPE	VULCAN+	EMPEROR	2F + CLAMP	2A CLAMP
24	56	SFT26	VRT+03	ES51-59	2F+09	2A-09
25	58	SFT26	VRT+03	ES51-59	2F+10	2A-10
26	59	SFT26	VRT+03	ES51-59	2F+10	2A-10
27	61	SFT26	VRT+04	ES58-66	2F+10	2A-10
28	63	SFT26	VRT+04	ES58-66	2F+10	2A-10
28	64	SFT31	VRT+05	ES58-66	2F+11	2A-11
29	66	SFT31	VRT+05	ES65-73	2F+11	2A-11
30	68	SFT31	VRT+05	ES65-73	2F+11	2A-11
31	70	SFT31	VRT+06	ES65-73	2F+1200	2A-1200
32	71	SFT31	VRT+06	ES65-73	2F+1200	2A-1200
33	73	SFT31	VRT+06	ES65-73	2F+1200	2A-1200
34	75	SFT31	VRT+06	ES73-85	2F+1200	2A-1200
33	76	SFT36	VRT+06	ES73-85	2F+1201	2A-1201
34	78	SFT36	VRT+06	ES73-85	2F+1201	2A-1201
35	80	SFT36	VRT+07	ES73-85	2F+1201	2A-1201
36	82	SFT36	VRT+07	ES73-85	2F+1201	2A-1201
37	83	SFT36	VRT+07	ES73-85	2F+1202	2A-1202
38	84	SFT36	VRT+07	ES73-85	2F+1202	2A-1202
39	86	SFT36	VRT+08	ES84-94	2F+1202	2A-1202
39	88	SFT43	VRT+08	ES84-94	2F+1202	2A-1202
40	89.5	SFT43	VRT+08	ES84-94	2F+1202	2A-1202
41	93	SFT43	VRT+08	ES84-94	2F+131	2A-131
42	94	SFT43	VRT+09	ES84-94	2F+131	2A-131
43	95	SFT43	VRT+09	ES94-118	2F+131	2A-131
44	97	SFT43	VRT+09	ES94-118	2F+131	2A-131
45	99	SFT43	VRT+10	ES94-118	2F+132	2A-132
46	102	SFT43	VRT+10	ES94-118	2F+132	2A-132
47	104.5	SFT43	VRT+11	ES94-118	2F+132	2A-132
47	105	SFT51	VRT+11	ES94-118	2F+132	2A-132
48	107	SFT51	VRT+11	ES94-118	2F+141	2A-141
49	110	SFT51	VRT+12	ES94-118	2F+141	2A-141
50	112	SFT51	VRT+12	ES94-118	2F+141	2A-141
51	114	SFT51	VRT+12	ES94-118	2F+142	2A-142
52	117	SFT51	VRT+12	ES94-118	2F+142	2A-142
53	119.5	SFT51	VRT+13	ES118-130	2F+142	2A-142
54	121	SFT51	VRT+13	ES118-130	2F+151	2A-151
55	123.5	SFT51	VRT+13	ES118-130	2F+151	2A-151

\*\*\*For part numbers in red the wider SFT2F+ needs to be used to suit the increased depths of the clamps\*\*\*

# OUR HANGERS



Alongside our market-leading cable cleats, Ellis offers a comprehensive range of cable hangers, providing safe, durable, and efficient cable support for demanding applications.

Each design is rigorously tested to the highest industry standards and manufactured under strict accreditation processes to guarantee performance and compliance.

Our Pegasus® Hanger range, developed in close partnership with London Underground, exemplifies this commitment to innovation and safety. Pegasus® offers unrivalled reliability for some of the world's most challenging operating conditions.



Scan here  
to see our  
Hanger Brochure

Pegasus® Retrofit Cable Hangers



Pegasus® Multi-Fix Cable Hangers



Pegasus® Composite Hanger System



Ellis Convex Cable Hangers



KNOWLEGE

SAFETY

COMMITMENT

# SUSTAINABILITY



At Ellis, sustainability isn't a trend - it's a long-standing commitment woven into every aspect of our operations. Over the past seven years, we've reduced our carbon footprint by 55%, far surpassing industry targets. Today, 57% of our energy comes from solar power, thanks to the installation of 869 solar panels across our facilities.

## Taking responsibility

We prioritise responsible manufacturing by maximising the use of recycled and recyclable materials wherever performance allows, without compromising safety or quality. Our investment in modern, energy-efficient machinery reduces energy consumption, minimises waste and improves production efficiency, ensuring every product is made with environmental impact firmly in mind.

## Driving change

We proudly operate with zero waste to landfill, and our energy-efficient practices - from LED lighting to electrified company vehicles - reflect our belief that environmental responsibility and business resilience go hand in hand. We have a dedicated energy team who meet regularly to continually challenge and find ways to improve our processes, driving our net-zero agenda continually forwards.

## Empowering others

We also lead the industry in transparency with the world's first Environmental Product Declaration for both stainless steel and polymer cable cleats. Independently verified and aligned with international standards (EN 15804+A2, ISO 14025, ISO 21930), this declaration provides a full lifecycle analysis of our products' environmental impact, enabling customers, suppliers, and distributors to make informed, sustainable choices.

## Redefining parameters

From reducing greenhouse gases to pioneering eco-conscious product reporting, we're setting the standard for sustainable cable management - proving that innovation and environmental stewardship can go hand in hand.

# ACCREDITATIONS & MEMBERSHIPS



We're fuelled by a shared passion to uphold and exceed the industry's highest standards, setting benchmarks that inspire others. With every project we undertake, and every innovation we champion, we forge ahead, reshaping the landscape of our industry and setting new standards as we go.

## Accreditations

Our vast and growing library of UK, European and global accreditations confirms our commitment to meeting the world's most rigorous standards.

## Membership

We believe in collaborating and leading by example, working with others to uphold and exceed the demands of our industry – while investing in its future.



# IEC 61914 TESTING PROCESS

## Demanding better

We were undertaking dynamic short circuit testing well before the inception of IEC 61914. We've conducted hundreds of short circuit tests globally, working both to IEC requirements and to bespoke customer specifications. This experience makes us the recognised authority in determining cleat performance under fault conditions.

Our IEC 61914 compliant testing process includes:

### 1. Cleat Type

IEC 61914 classifies cleats into three categories:

#### Metallic

Manufactured entirely from metal.

#### Composite

Incorporating both metallic and polymeric components.

#### Non-metallic

Manufactured entirely from polymeric materials.

### 2. Temperature for Permanent Application

Definition: The ambient temperature range within which a cleat can operate.

IEC 61914 specifies standard test temperatures. These values represent ambient conditions only and should not be confused with maximum cable conductor temperatures.

MIN. TEMP °C	MAX. TEMP °C
+5	+40
-5	+60
-15	+85
-25	+105
-40	+120
-60	

### 3. UV Resistance

Composite and non-metallic cleats undergo UV resistance testing in accordance with ISO 4892-2. Samples are exposed to a minimum of 700 hours of xenon-arc UV light. Products pass if no visible cracking or degradation occurs and if they meet impact resistance criteria.

IEC 61914 UV classifications are limited to the test conditions defined in the standard. For more demanding environments (e.g. desert installations), Ellis offers in-house UV testing capabilities that replicate harsher conditions than those required by the standard.

### 4. Corrosion Resistance

Metallic and composite cleats are assessed for corrosion resistance. Components manufactured from non-ferrous alloys (e.g. aluminium) or stainless steels containing >16% chromium (e.g. 316L) are automatically classified as high resistance to corrosion. Other metals undergo 192 hours of salt spray testing to ISO 9227. Passing requires no visible red rust.

As with UV testing, the IEC 61914 classification is limited to the scope of the standard. Ellis supplements this with extended outdoor weathering trials at our dedicated corrosion testing station to provide more accurate performance data for harsh environments.



## 5. Impact Rating

Impact performance is determined by dropping a weight from a specified height onto the cleat. For polymeric cleats, tests are conducted at their minimum declared operating temperature. For metallic cleats, testing is carried out at room temperature.

A cleat passes if it shows no damage that would compromise load-holding capability. This test is representative of site handling conditions, including accidental drops or falling tools.

Classification	Nominal impact energy (J)	Equivalent mass (KG)	Height (MM)
Very light	0.5	0.25	200
Light	1.0	0.25	400
Medium	2.0	0.5	400
Heavy	5.0	1.7	300
Very heavy	20.0	20.0	400

Figures taken from IEC 61914

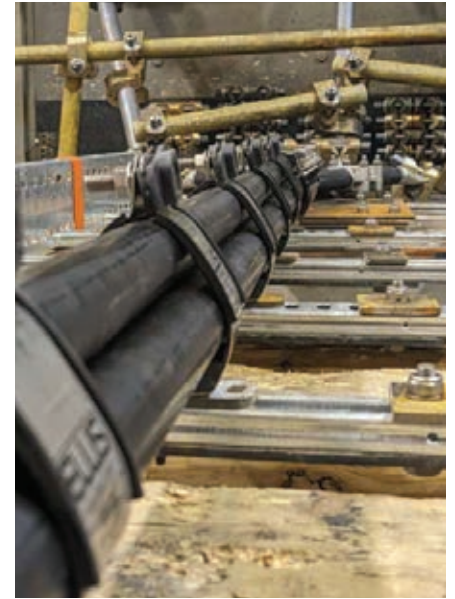

## 6. Flame Propagation

Composite and non-metallic cleats are subjected to a needle flame test (IEC 60695-11-5) to determine their contribution to fire. Passing criteria:

- Any material dripping must not ignite tissue paper placed below.
- No flaming of the cleat after 30 seconds once the flame is removed.

Passing this test confirms that a cleat will not propagate fire from a small ignition source. It does not qualify the product as fire-rated. Ellis manufactures cleats predominantly from flame-retardant polymers, with cost-effective non-FR materials available for non-critical applications.

## 7. Axial Load Rating

The axial load rating defines a cleat's grip strength on a cable. A declared load is applied to a mandrel for five minutes. The cleat passes if mandrel movement is less than 5 mm.

- Composite and non-metallic cleats are tested at maximum declared temperature.
- Metallic cleats are tested at room temperature.

This test provides key data for vertical installations where cleats must bear the full weight of the cable, and for systems requiring resistance to thermomechanical axial thrust.

## 8. Lateral Load Rating

This test measures a cleat's ability to withstand continuous side-loading. A declared load is applied for one hour. The cleat passes if deformation is less than 50% of the minimum cable diameter accommodated. Testing is carried out under two mounting orientations (horizontal and vertical). As with axial load, composite and non-metallic cleats are tested at maximum declared temperature; metallic cleats at room temperature. The lateral load rating is especially relevant when cleats are mounted on their side or subject to continuous loading. Note that this test does not assess short-circuit performance.

- A manufacturer-declared peak current applied for  $\geq 0.1s$ .
- Test cables: unarmoured single-core copper conductors, 600 V/1,000 V rated, with  $35 \pm 5$  mm or  $50 \pm 5$  mm OD.
- Testing at prevailing laboratory ambient temperature.
- Trefoil or flat formations.

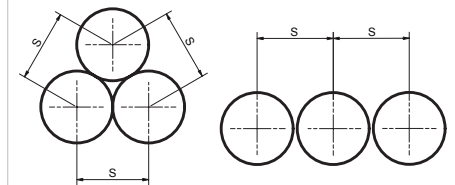

## 9. Resistance to Electromechanical Force

The most critical test under IEC 61914 is short circuit performance. Cable cleats must withstand the electromechanical forces generated during a three-phase fault. Key elements of the test include:

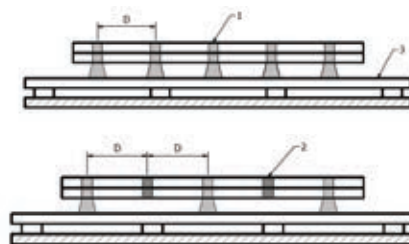

Key	Description
1	Cable Cleats
2	Intermediate Restraints
3	Mounting Surface
D	Lineal Spacing

- At least five cleats for full cleat testing; at least four cleats and three intermediate straps for cleat/strap assemblies.

Pass criteria after one short circuit:

- Cleats and straps remain intact, securing cables without missing components.
- No sheath damage visible to normal or corrected vision.

Optional second short circuit:

- First-test criteria apply.
- The rig must pass a dielectric withstand test (2.8 kV DC or 1.0 kV AC for 60s) with cable jackets and mounting frame pre-wetted.

# DESIGNING FOR THERMAL EXPANSION

Power cable systems which consider the effects of thermal expansion are critical for ensuring the longevity and safety of infrastructure and personnel.

Our cleated cable installations typically utilise two methods to accommodate for thermal expansion:

## Rigid Installation



For rigid installations which are not buried, the cable must be cleated at short intervals to prevent movement. The cable supports must be strong enough to resist thermal expansion and contraction, and ensure the cable withstands the thrust force.

Cleats that offer a high axial thrust restraint, such as the Ellis 2A clamp, are best suited to rigid type systems.

## Flexible Installation



In flexible systems, the cable is laid in a snaked formation, either vertically or horizontally. The support system must allow for expansion and contraction, and be capable of withstanding variable thrust force.

Cable snake geometry is determined based on the system requirements, taking into account factors like metallic sheath fatigue characteristics, space limitations and cable bending stiffness.

Cleats such as the Ellis Centaur are best suited to vertically snaked systems, with a large base to properly support the cable across the large span. There are a variety of excellent options for horizontal systems.

---

## CASE STUDIES

Here are just a few examples of the bespoke solutions the Ellis team have worked on in partnership with our customers across the diverse industries we operate in.



Tight radius install an offshore wind farm sub station



Fort Randall, cable saddles in hydro electric dam

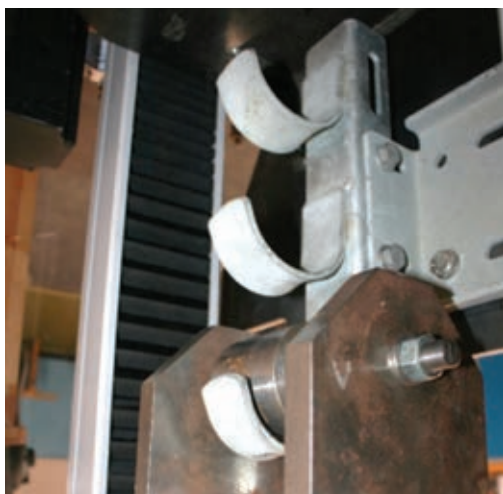

Cable hangers for London Underground



Duct support under a road bridge

You can find more details about these and many other case studies on our website.





# ELLIS

Holding Power

Ellis Patents Ltd  
High Street,  
Rillington, Malton,  
North Yorkshire  
YO17 8LA  
United Kingdom

T +44 (0)1944 758 395  
sales@ellispatents.co.uk  
www.ellispatents.co.uk